

Assembly Instructions *Instructions de montage* *Instrucciones de armado*

Two Drawer Tall Nightstand *Table de chevet à deux tiroirs* *Mesilla de noche con 2 cajones*

DATE STAMP

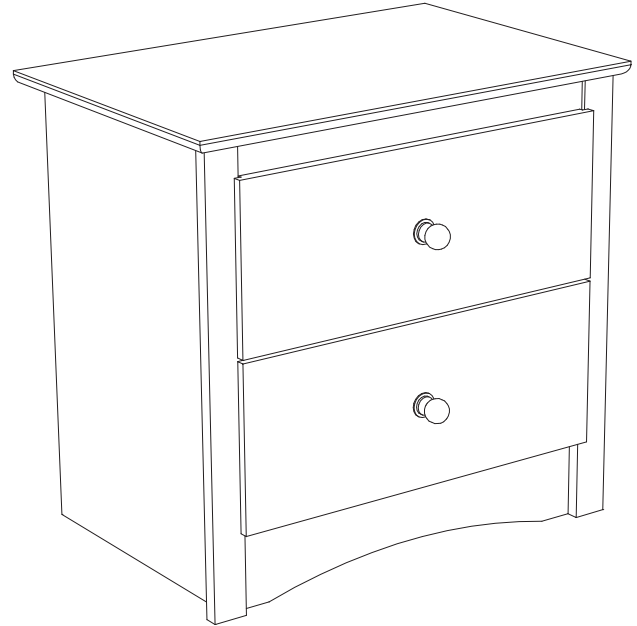
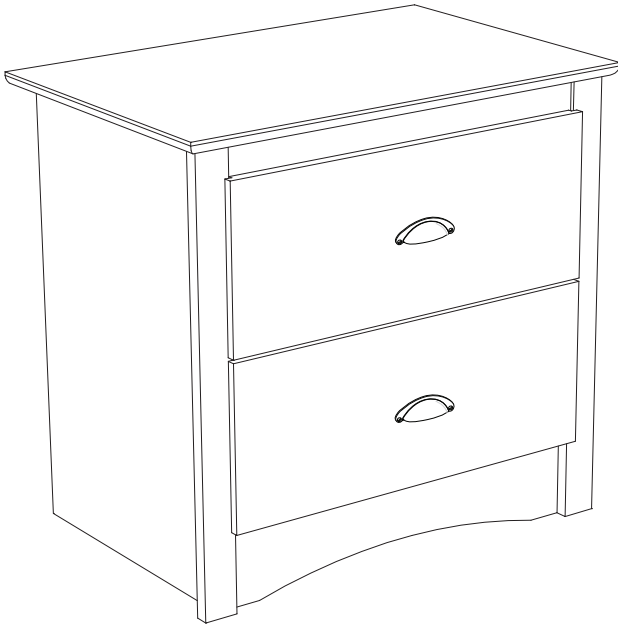

CONTACT US FIRST

parts@prepacmfg.com
1-877-PREPAC1
1-877-773-7221

Mon - Fri: 7am - 4pm PST / 10am - 7pm EST

- For help with assembly
- If you have received a damaged or defective part or are missing hardware.

We will process replacement parts in 2 business days or less. Parts are shipped via UPS Ground or mail.

Before you call please:

- 1) Record the following information from the shipping label on the outside of the box. You will need it for warranty purposes:
 - Ship To Name
 - Sales Order Number
- 2) Note the product model number.
- 3) Review the contents of your shipment to determine what you are missing.

Online Option

Fill out the Replacement Parts Order form in the Product Support section of our website: www.prepacmfg.com

Option de service en ligne

Complétez le formulaire Commande de Pièces de Rechange disponible dans la section Soutien à la clientèle de notre site web : www.prepacmfg.com

Pour parler avec quelqu'un en français, s'il vous plaît contacter votre détaillant.

Opción de servicio en línea

Complete la forma para solicitud de piezas de remplazo en la sección de soporte al cliente en nuestra página web www.prepacmfg.com

***O envíenos sus preguntas al correo parts@prepacmfg.com
Para solicitar ayuda en español por favor contacte su distribuidor.***

Nightstand Hardware / Quincaillerie de la table de nuit / Piezas de la mesilla de noche

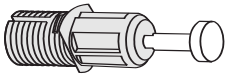

Blue Rapid Rod (12)
Tige rapide bleu
Clavija azul de ajuste rápido
RM-0583



Large Zinc Cam (15mm) (12)
Ferrure en zinc grand (15mm)
Tuercas de fijación grande de zinc (15mm)
RM-0103

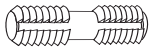

Plastic Dowel (2)
Goujon en plastique
Clavija de plastico
RM-0072



Wood Dowel (4)
Goujons de bois
Clavija de madera
RM-0069

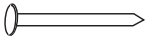

3/4" Nail (16)
Clou 3/4"
Clavo de 3/4 pulg.
RM-0022



Drawer Slide Screw (8)
Vis pour coulisse de tiroir
Tornillos para rieles de cajón
RM-0074

Drawer Hardware / Quincaillerie de tiroir / Piezas de los cajones

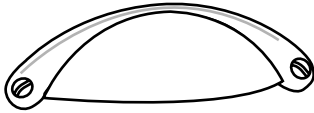

Hooded Cup Handle with Screws (2)
Poignée à capuchon avec vis
Manija encapuchada con tornillos
RM-0847
for drifted gray
à gris vieilli /
para gris madera



#8-32mm Machine Screw (2)
Vis de machine de 32mm
Tornillo para máquina de 32mm pulg.
RM-0465

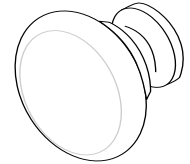

Knob (2)
Poignée
Perilla
RM-0464 black / noir / negro
RM-0464E espresso / expresso
RM-0625 cherry / cerise / cereza
RM-0625 white / blanc / blanco

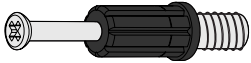

34mm Black
Twister Dowel (8)
Goujon de torsion noir
RM-0500



#8 - 1 1/2" Screws (8)
Vis no.8 - 1 1/2 po.
Tornillo de 1 1/2"
RM-0504



12mm Zinc Cam (8)
Ferrure en zinc 12mm
Tuercas de fijación
pequeña de zinc 12mm
RM-0715



Drawer Slide Screw (8)
Vis pour coulisse de tiroir
Tornillos para rieles de cajón
RM-0074

Separate the Drawer Slide Set and identify components for the left and right sides

Séparer le jeu de glissières du tiroir et identifier les composants pour les côtés gauche et droit

Separate the drawer slide set and identify the components for the left and right sides

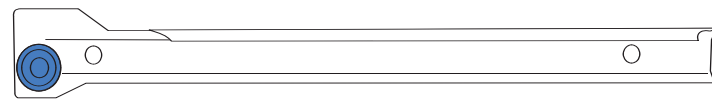

1 LEFT Cabinet Slide per Drawer
1 Glissière **GAUCHE** De Cabinet
1 riel del mueble **IZQUIERDO**
RM-0469-G

Blue Wheel
La roue bleu
La rueda azul

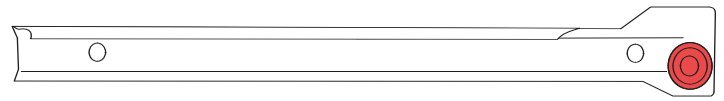

x2 1 RIGHT Cabinet Slide per Drawer
1 Glissière **DROITE** De Cabinet
1 riel del mueble **DERECHO**
RM-0469-G

Red Wheel
La roue rouge
La rueda roja

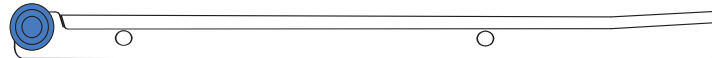

1 LEFT Drawer Slide per Drawer
1 Glissière **GAUCHE** de tiroir par tiroir
1 riel de cajón **IZQUIERDO**
RM-0469-G

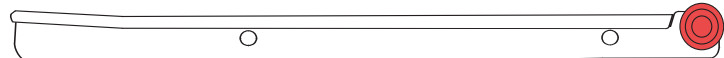

x2 1 RIGHT Drawer Slide per Drawer
1 Glissière **DROITE** de tiroir par tiroir
1 riel de cajón **DERECHO**
RM-0469-G



ONLINE HELP

Go to the Product Support page on our website:

L'AIDE EN LIGNE

Consultez la page de "Product Support" sur notre site web :

AYUDA EN LINEA

Dirijase a la sección "Product Support" en nuestra pagina web:

Note: glides and slides are used interchangeably

Remarque: les glissements et les glissières sont utilisés de manière interchangeable

Nota: los rieles se usan de forma intercambiable

www.prepacmfg.com/content/assembly

C1

Top (1)
Dessus
Superior

TP-10083-B black
TP-10088-CN cherry
TP-10083-D drifted gray
TP-10083-E espresso
TP-10088-W white

C2

Top Moulding (1)
Moulure supérieure
Moldura superior

TR-10079-B black
TR-10079-CN cherry
TR-10079-D drifted gray
TR-10079-E espresso
TR-10079-W white

C3

Left Side (1)
Côté gauche
Lado izquierdo

SL-10069-B black
SL-10069-CN cherry
SL-10069-D drifted gray
SL-10069-E espresso
SL-10069-W white

C4

Right Side (1)
Côté droit
Lado derecho

SR-10069-B black
SR-10069-CN cherry
SR-10069-D drifted gray
SR-10069-E espresso
SR-10069-W white

C5

Decorative Stabilizer A (1)
Stabilisateur décoratifs A
Estabilizador decorativo A

KR-10056-B black
KR-10063-CN cherry
KR-10056-D drifted gray
KR-10056-E espresso
KR-10063-W white

Cherry & White kickers have a different shape
Stabilisateurs cerise et blanc ont une forme différente
Los estabilizadores cereza y blancos tienen forma diferente

C6

Decorative Stabilizer B (1)
Stabilisateur décoratifs B
Estabilizador decorativo B

KR-10057-B black
KR-10057-CN cherry
KR-10057-D drifted gray
KR-10057-E espresso
KR-10057-W white

C7

Side Moulding (2)
Moulure latérale
Moldura lateral

TR-10053-B black
TR-10053-CN cherry
TR-10053-D drifted gray
TR-10053-E espresso
TR-10053-W white

C8

Backer (1)
Dos
Respaldo
BB-10051

black = noir / negro
cherry = cerise / cereza
drifted gray = gris vieilli / gris madera
espresso = espresso
white = blanc / blanco

See page 12 for Drawer Assembly
Voir page 12 pour l'assemblage de tiroir
Consulte la página 12 para ver el ensamblaje del cajón

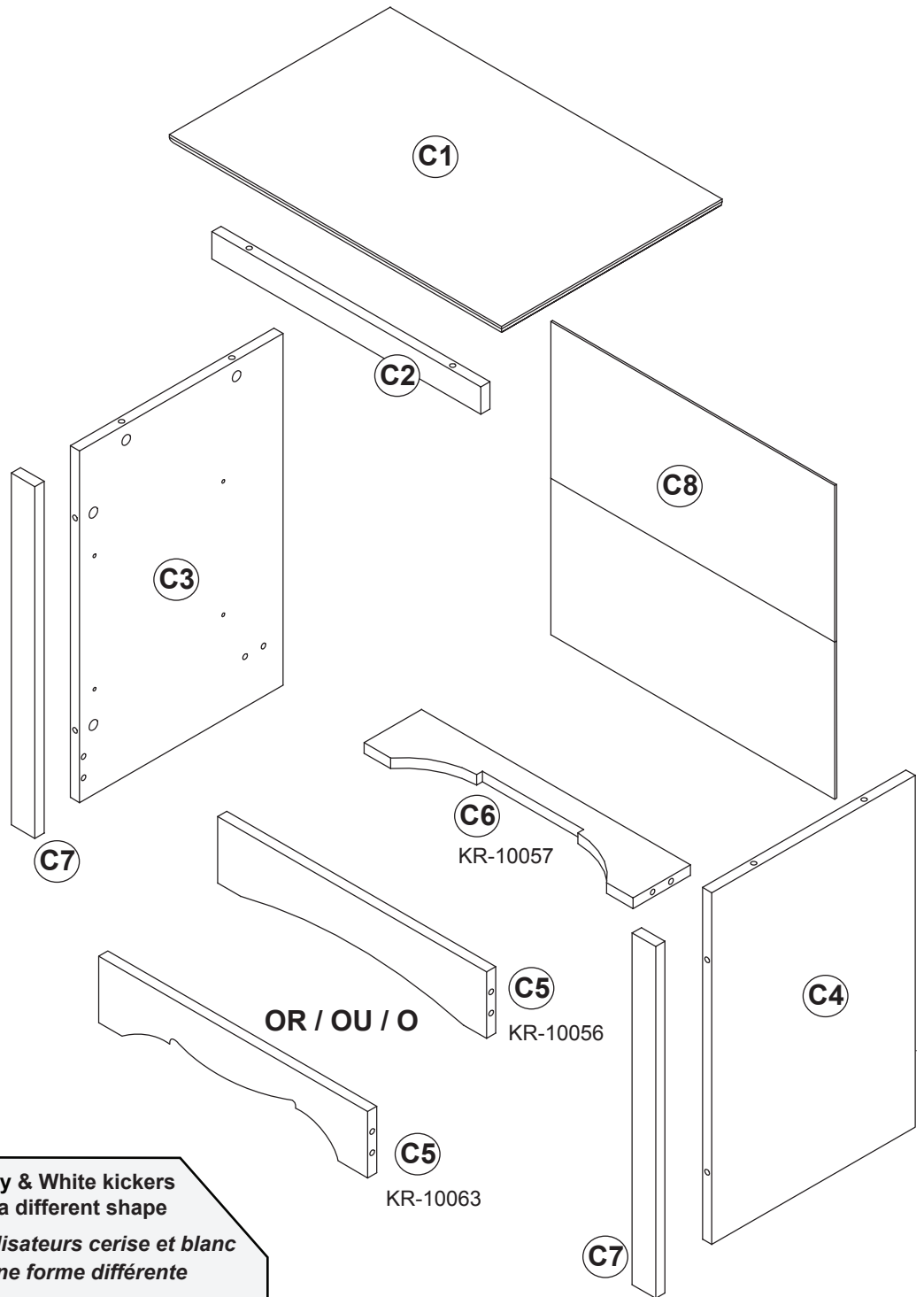

Required Tools / Outils requis / Herramientas necesarias

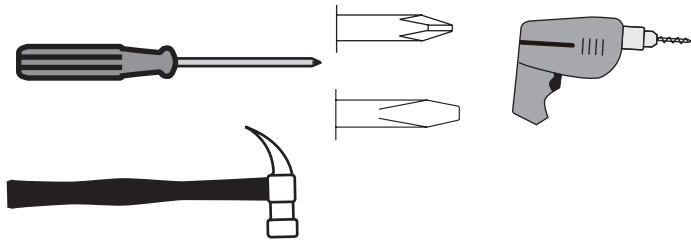

Caution

Do not over tighten any screw. The last few turns of each screw should be done very slowly or by hand.

Attention

Évitez de trop serrer les vis. Ralentissez la vitesse de la foreuse pour les derniers deux tours de vis ou vissez-les lentement à la main.

Precaución

No apriete los tornillos demasiado. Las últimas vueltas de cada tornillo deben hacerse muy lentamente o con la mano.



ONLINE HELP

To see how-to videos, go to the Product Support page on our website:

www.prepacmfg.com/content/assembly

L'AIDE EN LIGNE

Pour visionner les vidéo (en anglais) décrivant l'installation, consultez la page de "Product Support" sur notre site web : www.prepacmfg.com/content/assembly

AYUDA EN LINEA

Para ver videos de ayunda (en inglés), en nuestra pagina web click en las section "Product Support" www.prepacmfg.com/content/assembly

BEFORE YOU BEGIN

Identify ALL parts and hardware to ensure everything is included.

AVANT DE COMMENCER

Identifier toutes les pièces et le matériel afin de s'assurer que tout est inclus.

ANTES DE COMENZAR

Identifique todos las partes y componentes para estar seguro que todo está incluido

1

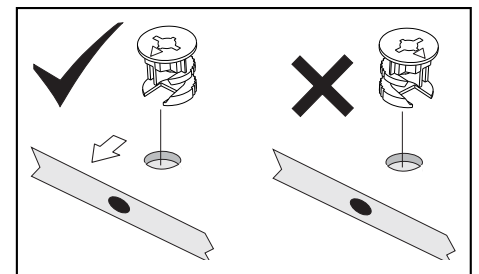
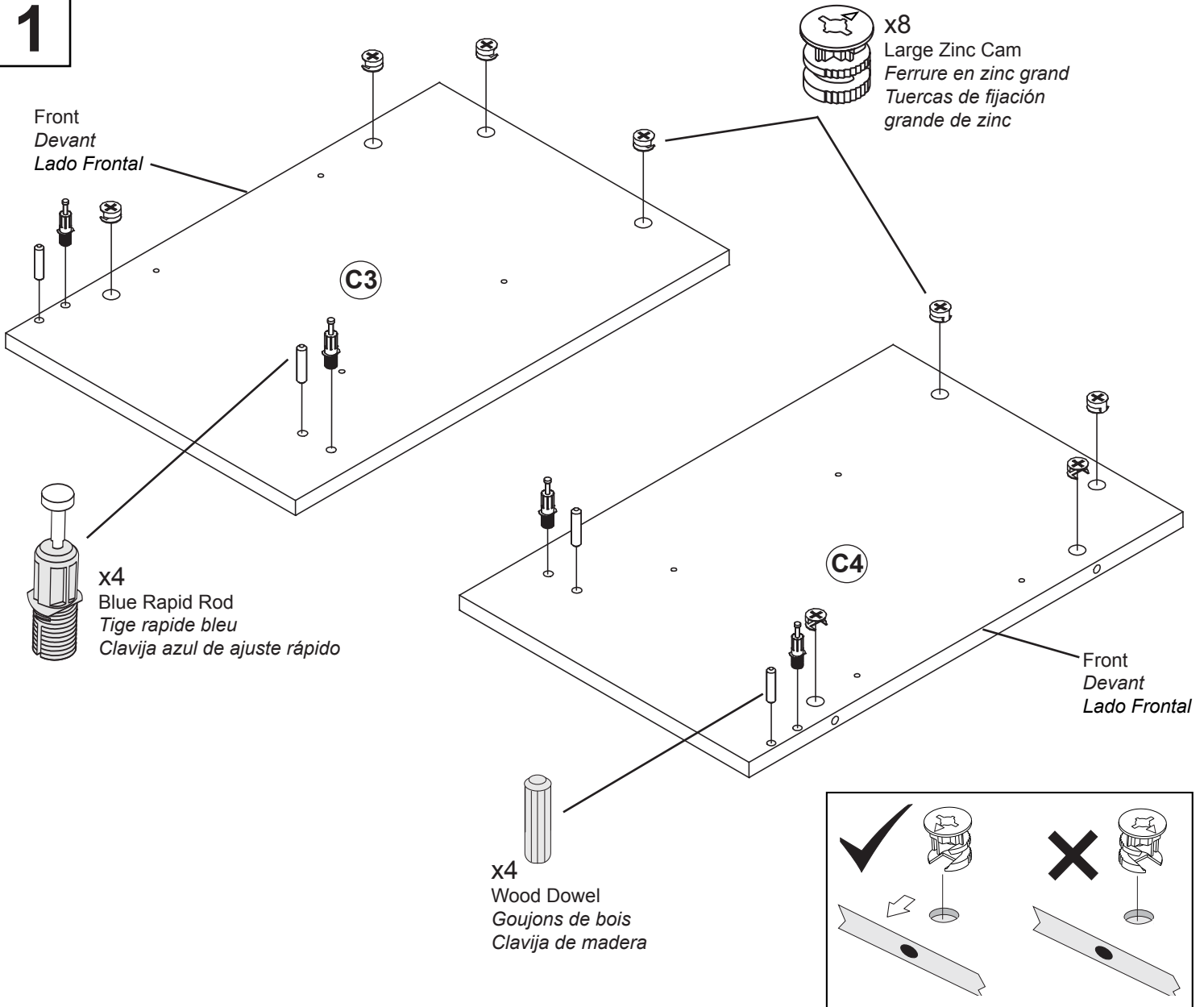

2

Attach Cabinet slides to left and right sides
Attachez des Glissière de cabinet aux côtés gauches et droits
Instale los rieles al lados izquierdos y derechos

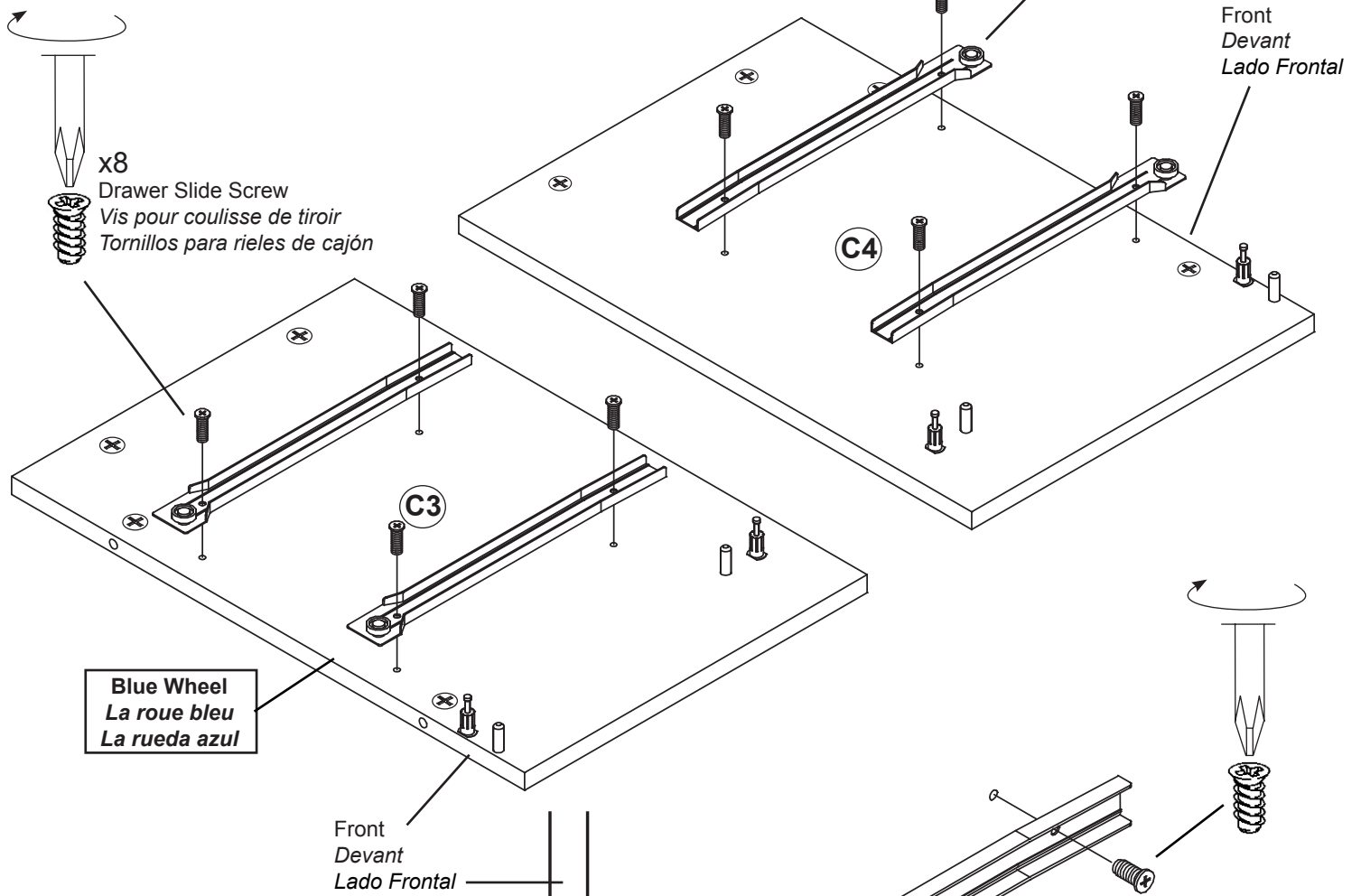

3

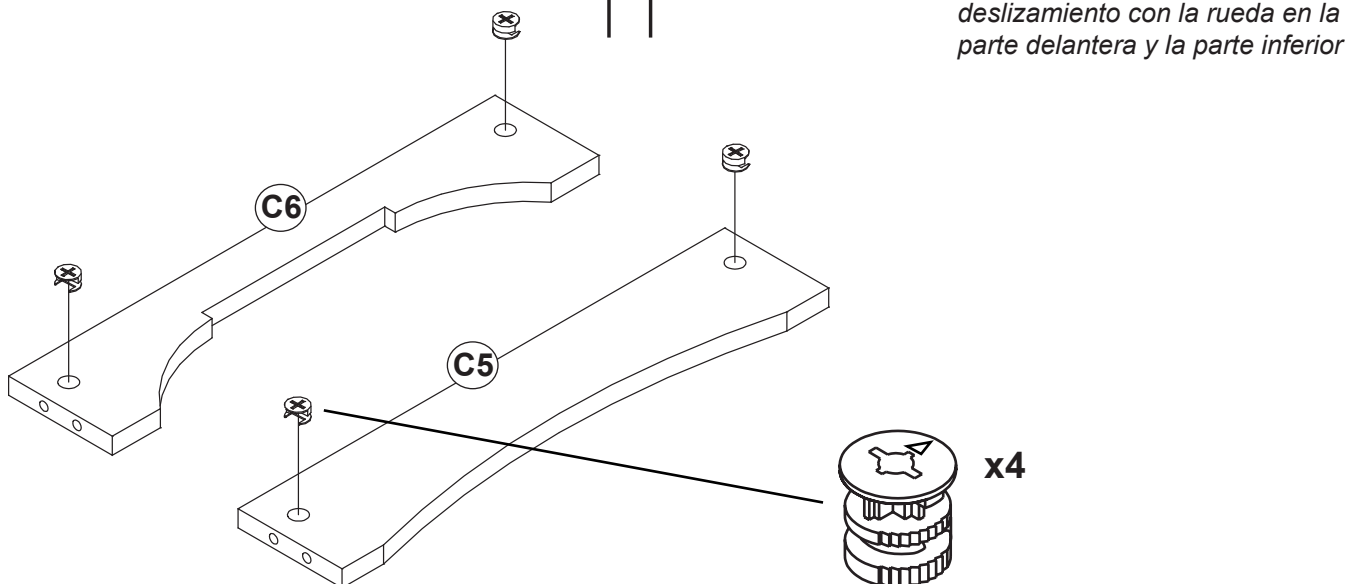

4

Decorative Stabilizers A (C5) and B (C6) are interchangeable. Choose the style that you prefer and attach it to the front. Attach the remaining stabilizer at the rear.

Stabilisateurs décoratifs A (C5) et B (C6) sont interchangeables. Choisissez le style que vous préférez et l'attachez à l'avant. Fixez le stabilisateur restant à l'arrière.

Los estabilizadores decorativos A (C5) y B (C6) son intercambiables. Elija el estilo que prefiera y fíjelo en la parte frontal. Fije el otro estabilizador en la parte posterior.

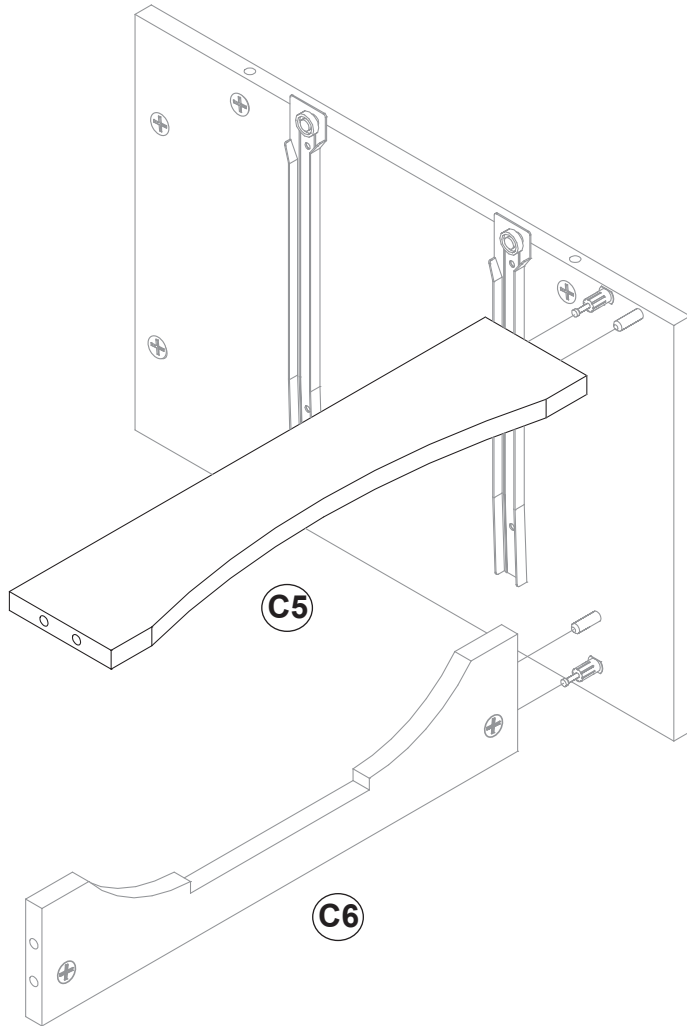

For simplicity, these instructions will only show ONE style of Stabilizer A (C5)

Pour la simplicité, ces instructions montreront seulement UN style de Stabilisateur A (C5)

Por simplicidad, estas instrucciones solo muestran un estilo de estabilizador A (C5)

**OR
OU
O**

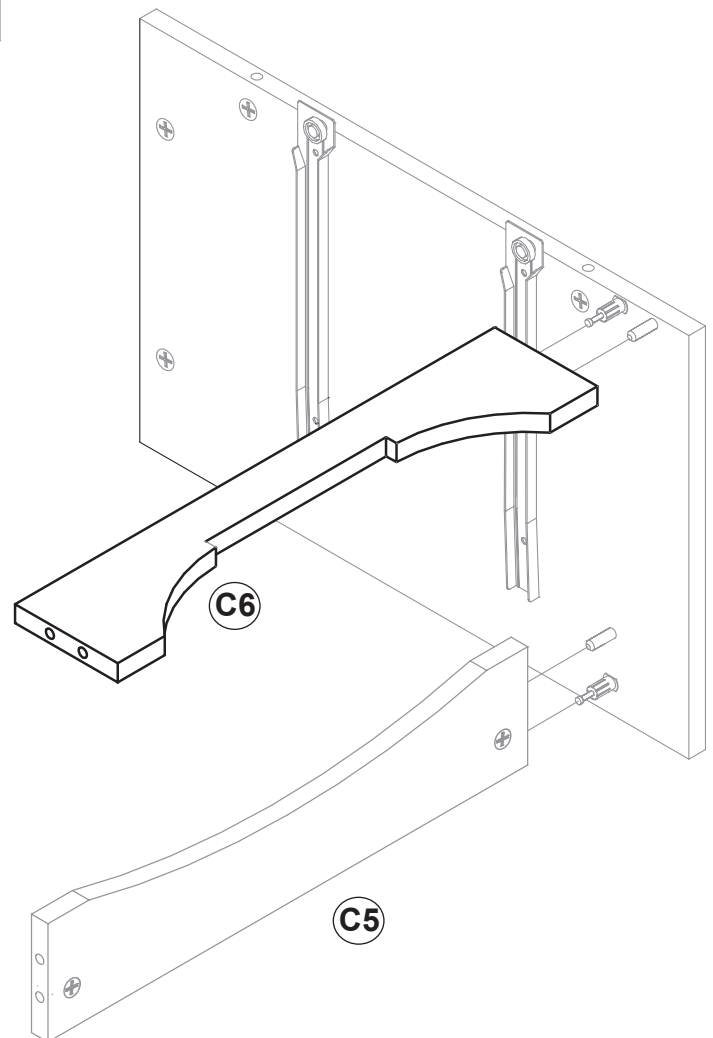

5

These instructions show Decorative Stabilizer A (C5) visible at the front
Ces instructions montrent le Stabilisateur Décoratif A (C5) visible à l'avant
Estas instrucciones muestran el estabilizador decorativo A (C5) visible en la parte frontal

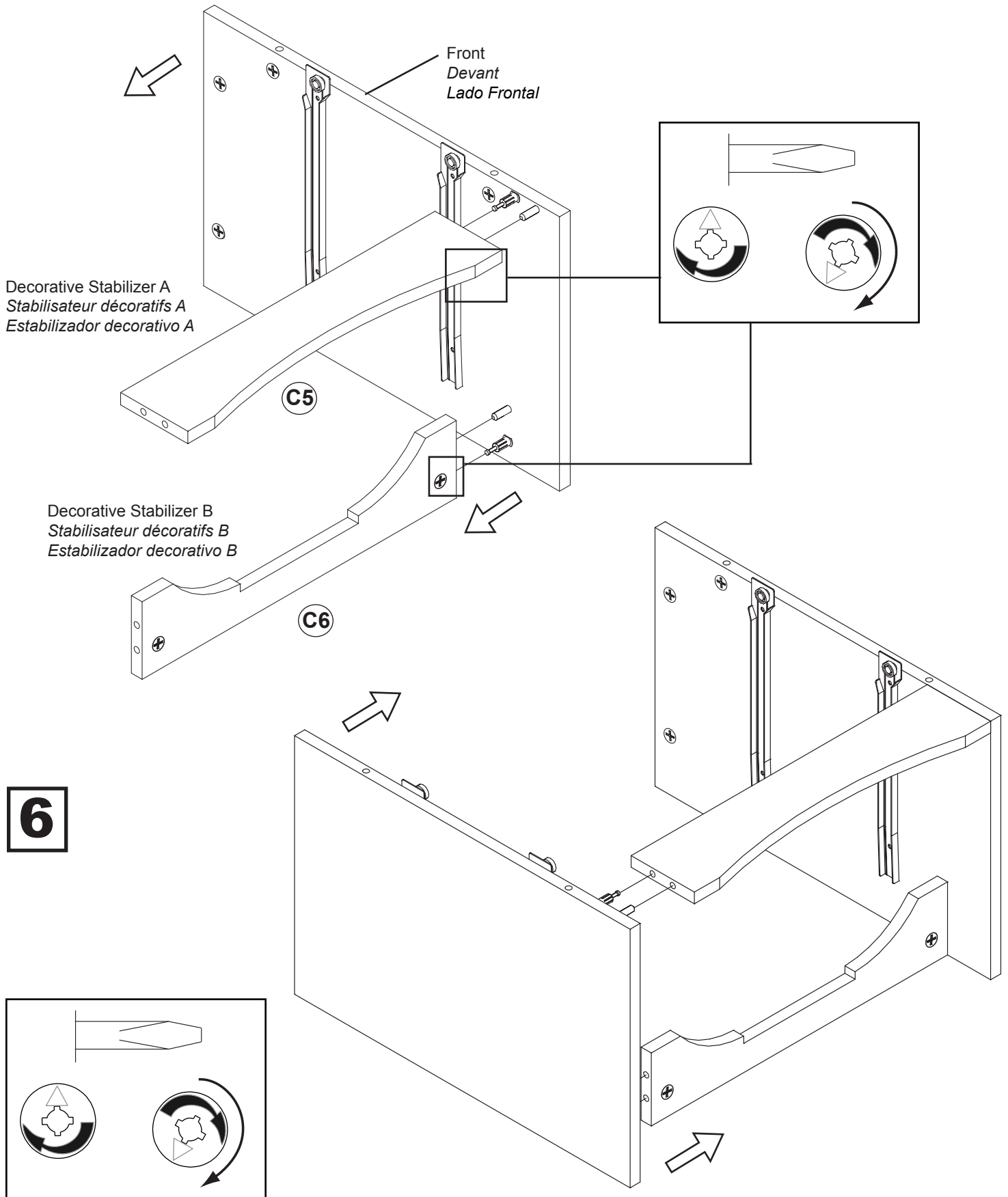

7

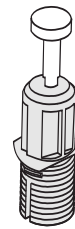
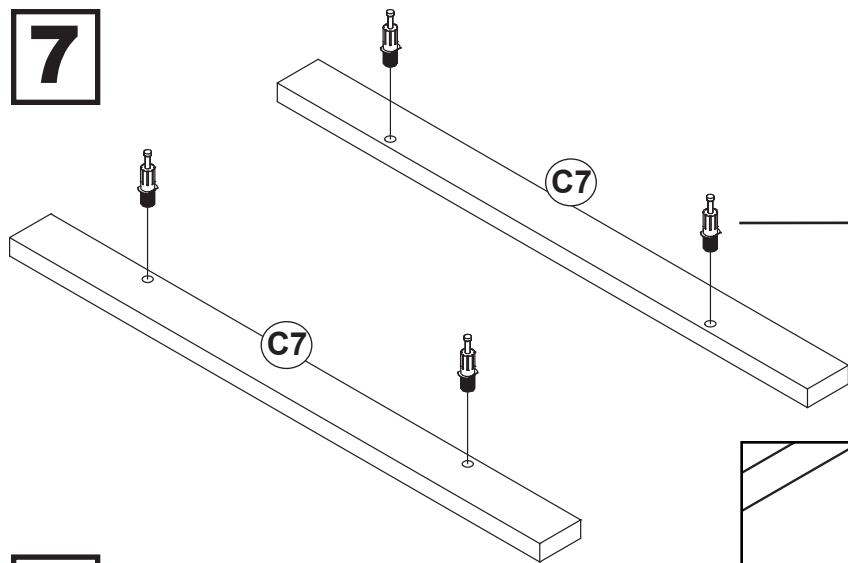

x4
Blue Rapid Rod
Tige rapide bleu
Clavija azul de ajuste rápido

8

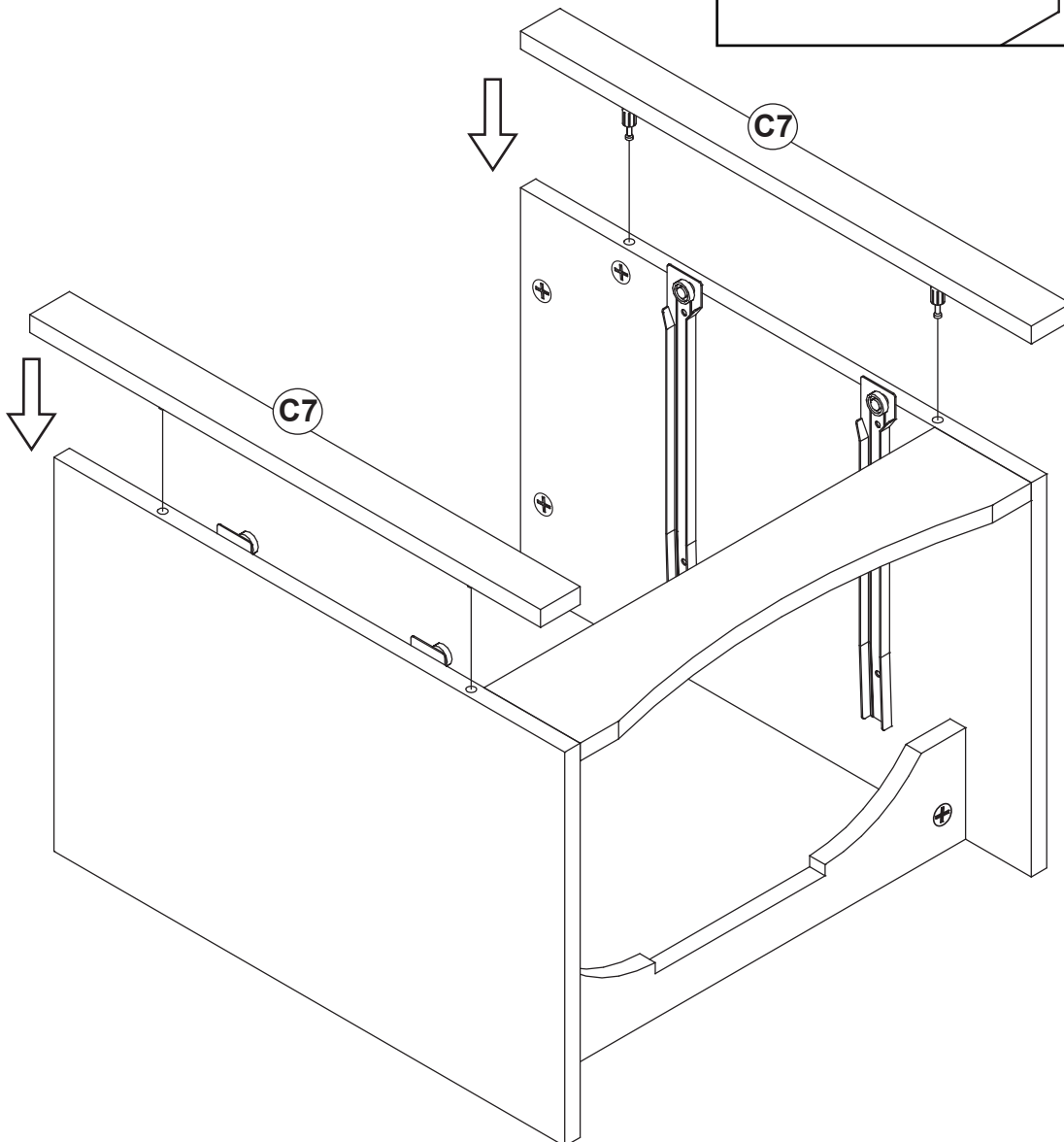
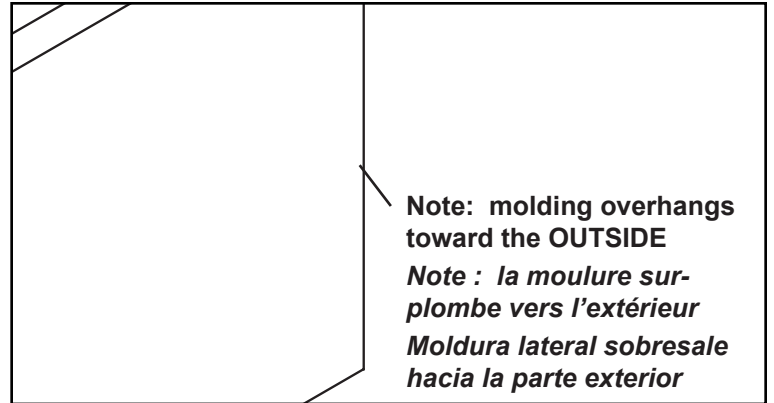

9

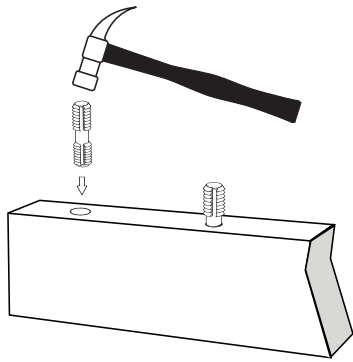

X2
Plastic Dowel
Goujon en plastique
Clavija de plastico

X4
Blue Rapid Rod
Tige rapide bleu
Clavija azul de ajuste rápido

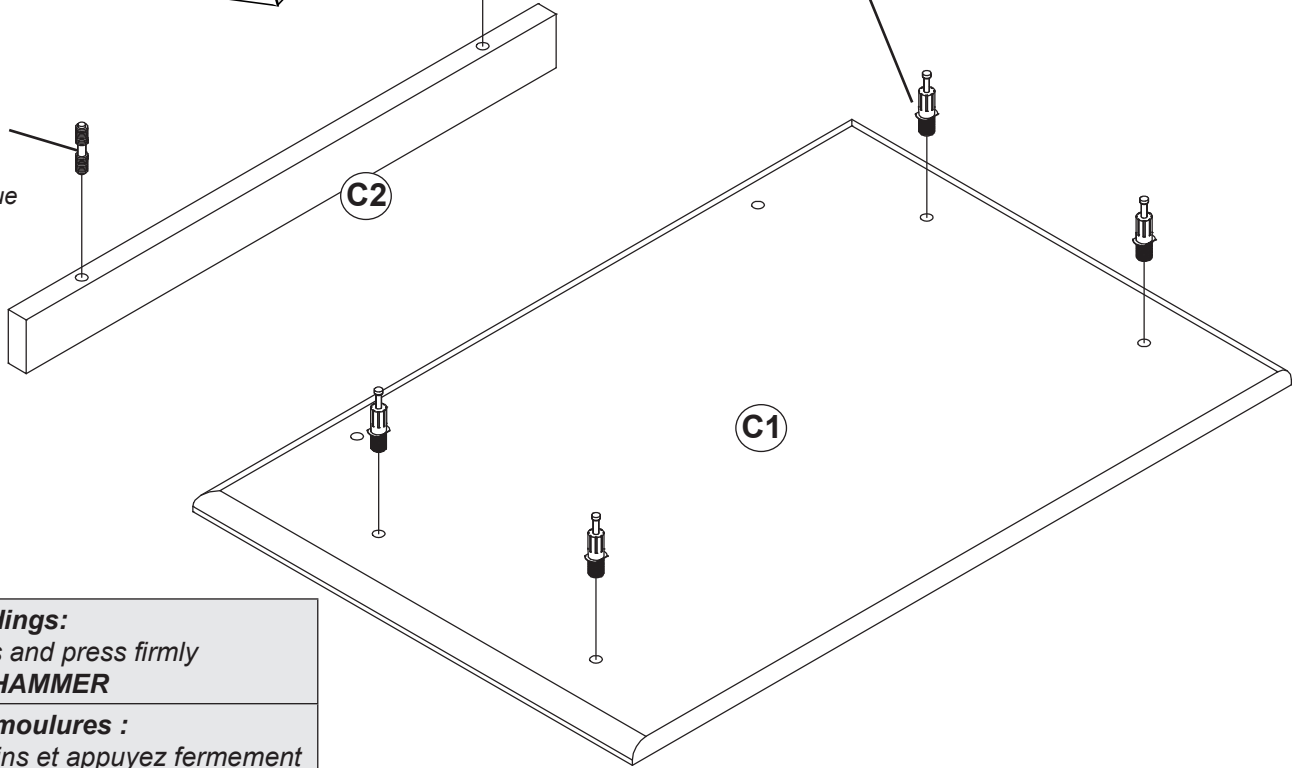

To attach moldings:
Use your hands and press firmly
DO NOT USE HAMMER

Pour fixer les moulures :
Utilisez vos mains et appuyez fermement
NE PAS UTILISER DE MARTEAU

Para colocar las molduras:
Use sus manos y presione firmemente
NO USE EL MARTILLO

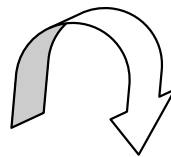

10

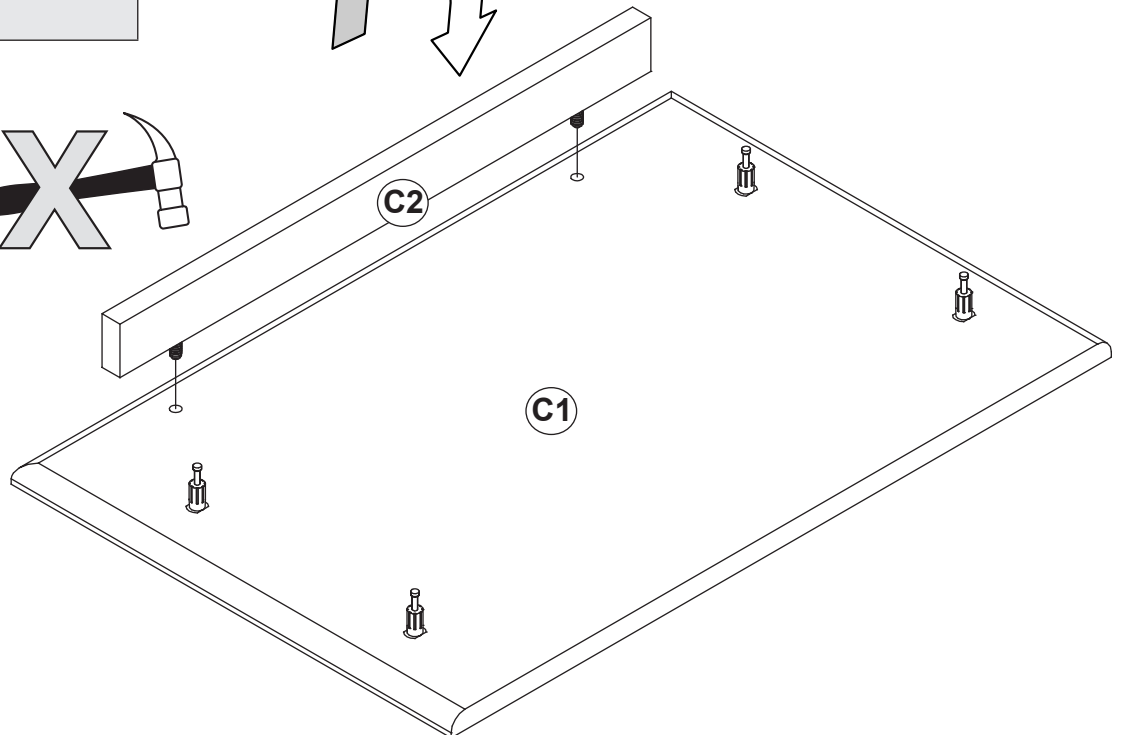

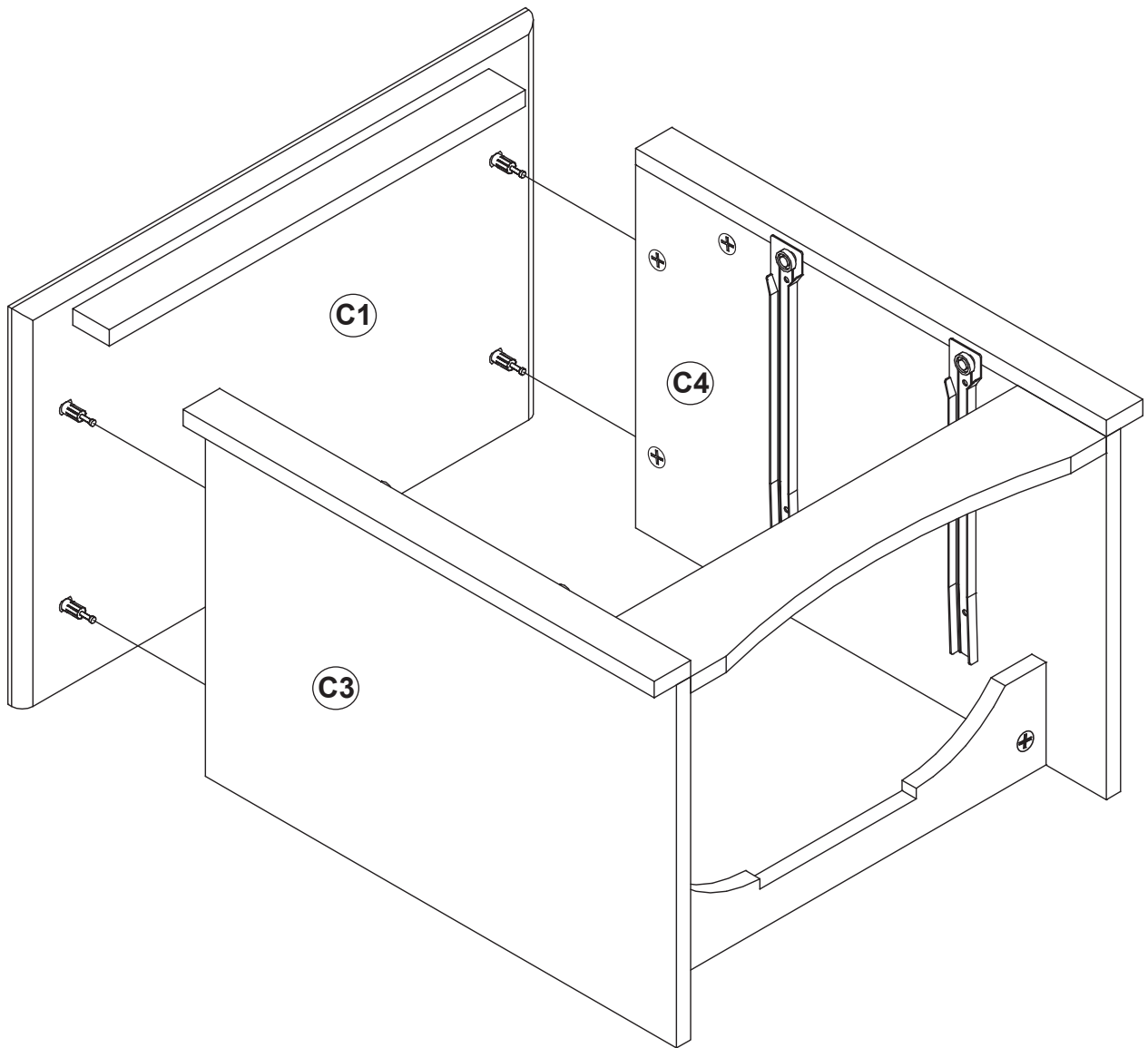

12

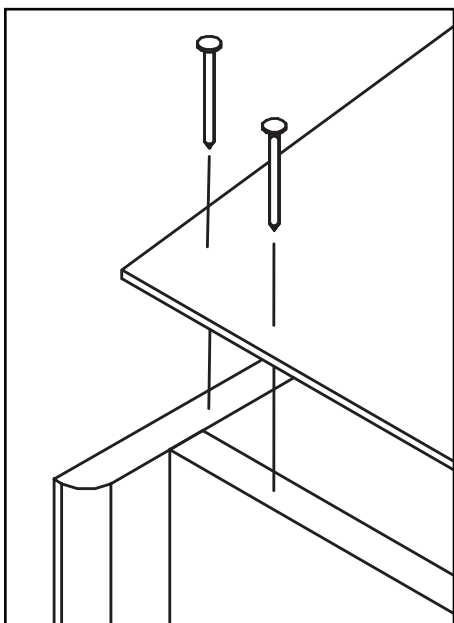
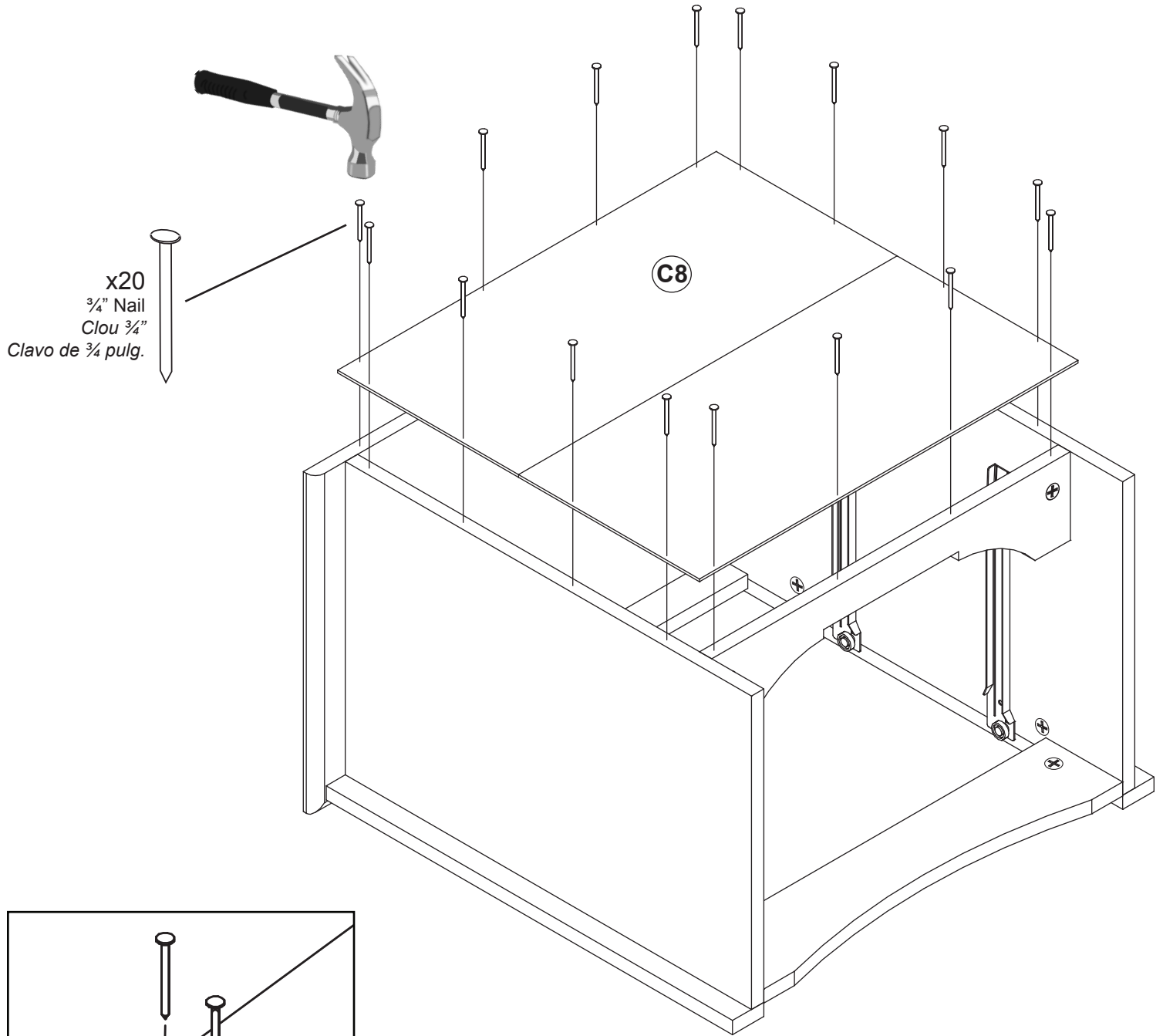

Center the nail in the middle of the panel. Avoid the corner of the backer
Centrez le clou au milieu sur le panneau. Évitez le coin du dos.
Centre el clavo en el medio del panel. Evite la esquina del respaldo.

13

Assemble Drawers Montez les tiroir Ensamble los cajones

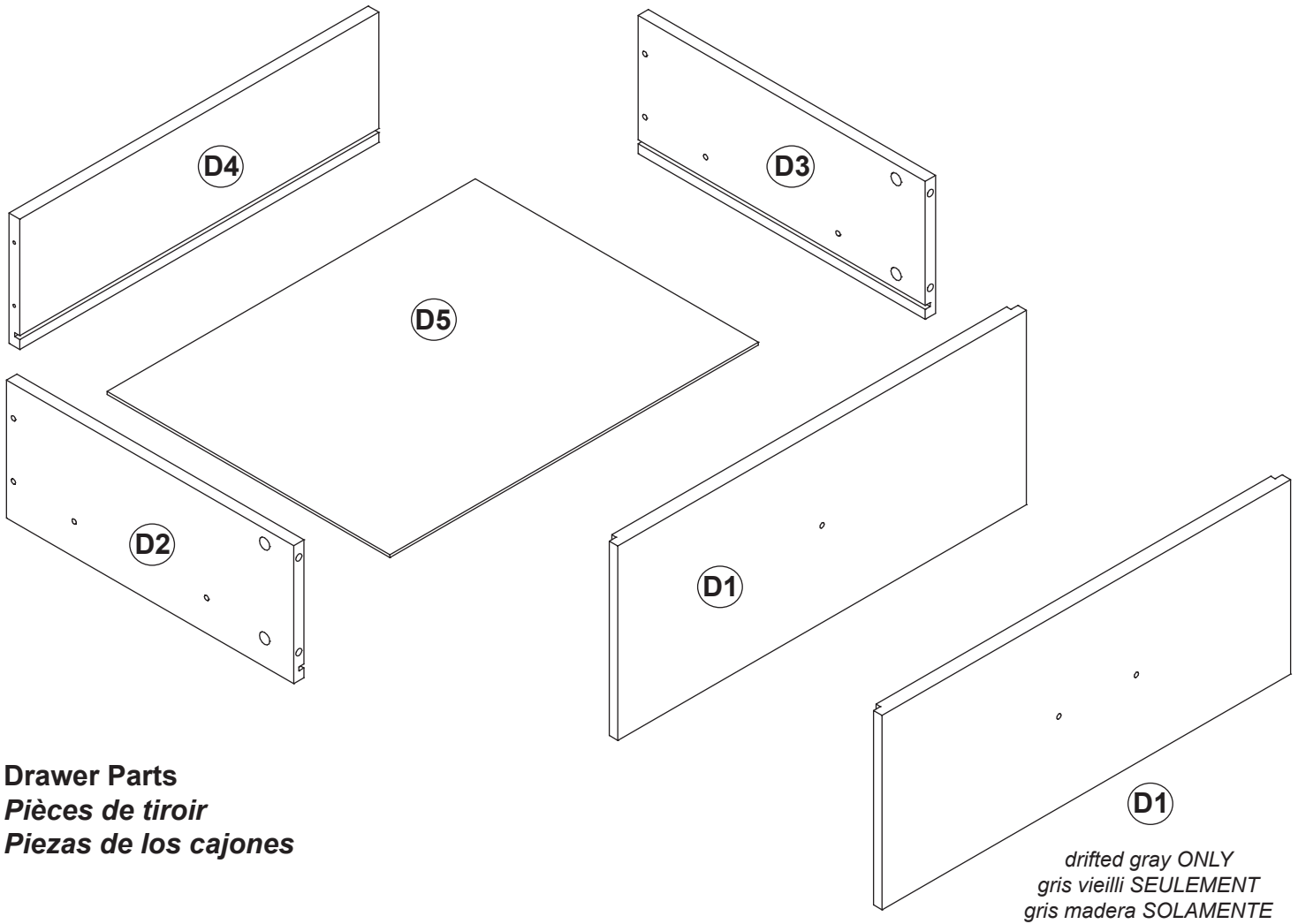

Drawer Parts Pièces de tiroir Piezas de los cajones

(D1)

Drawer Front (2)
Devant du tiroir
Frente del cajón

DF-10013-B
black / noir / negro

DF-10013-CN
cherry / cerise / cereza

DF-10027-D
drifted gray / gris vieilli /
gris madera

DF-10013-E
espresso / espresso

DF-10016-W
white / blanc / blanco

(D2)

Left Drawer Side (2)
Côté gauche du tiroir
Lado del cajón izquierdo

DS-10001-L
Unfinished
non-fini
sin acabado

(D3)

Right Drawer Side (2)
Côté droit du tiroir
Lado del cajón derecho

DS-10001-R
Unfinished
non-fini
sin acabado

(D4)

Drawer Back (2)
Arrière du tiroir
Parte posterior del cajón

DK-10044
Unfinished
non-fini
sin acabado

(D5)

Drawer Bottom (2)
Fond du tiroir
Fondo del cajón

DB-10044
Unfinished
non-fini
sin acabado

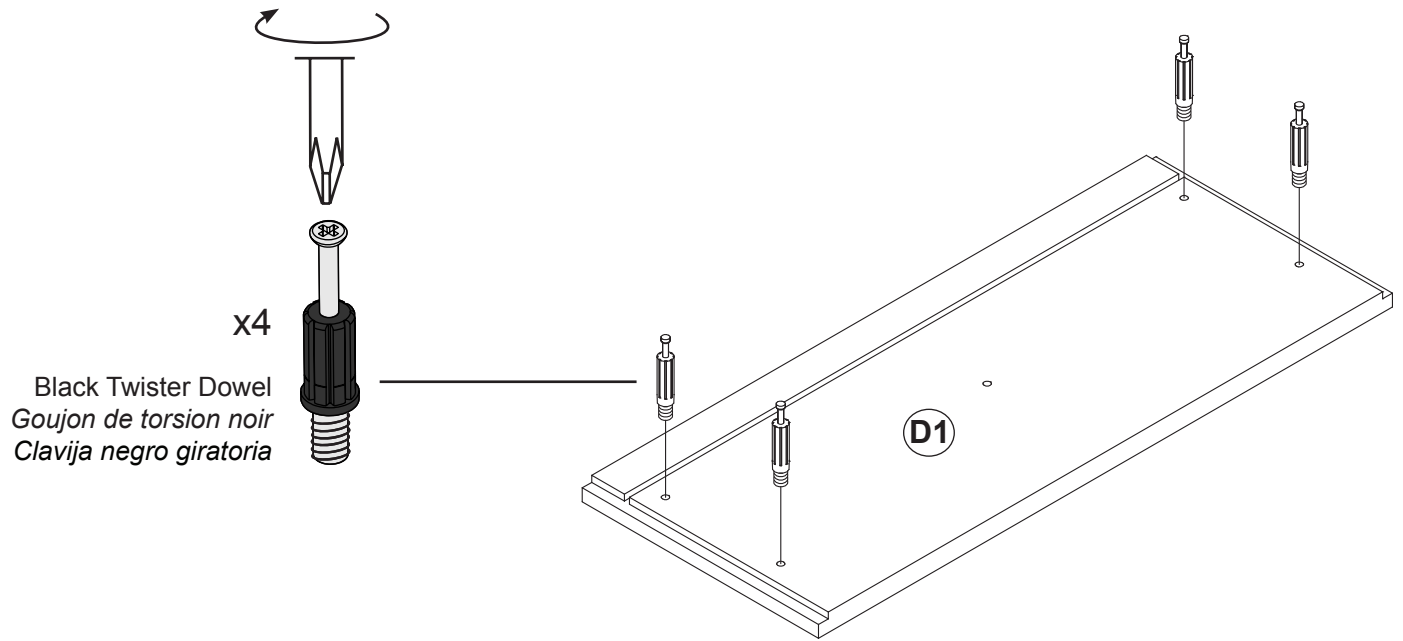
a**b**

Attach Drawer Slides to left and right sides
Attachez des Glissière du tiroirs aux côtés gauches et droits
Instale los rieles del cajón a lados izquierdos y derechos

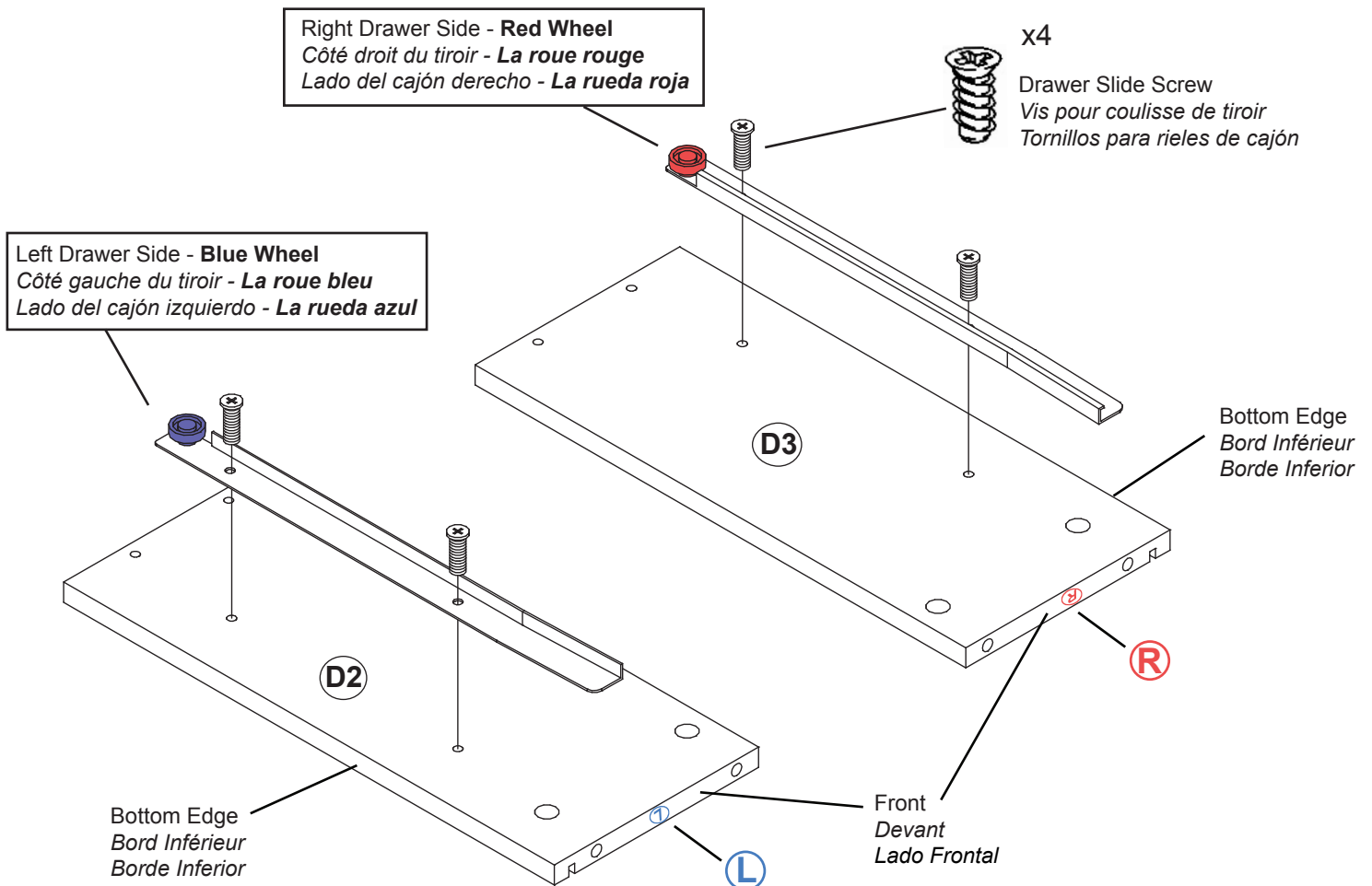

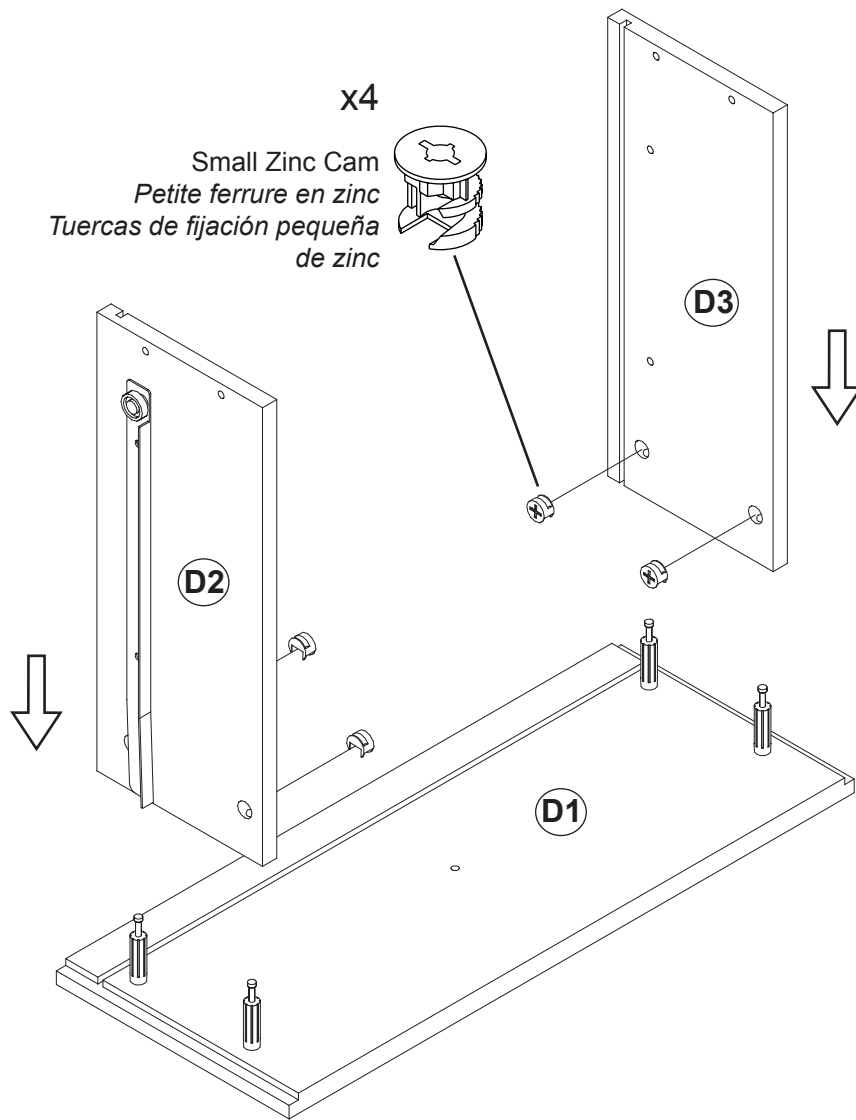
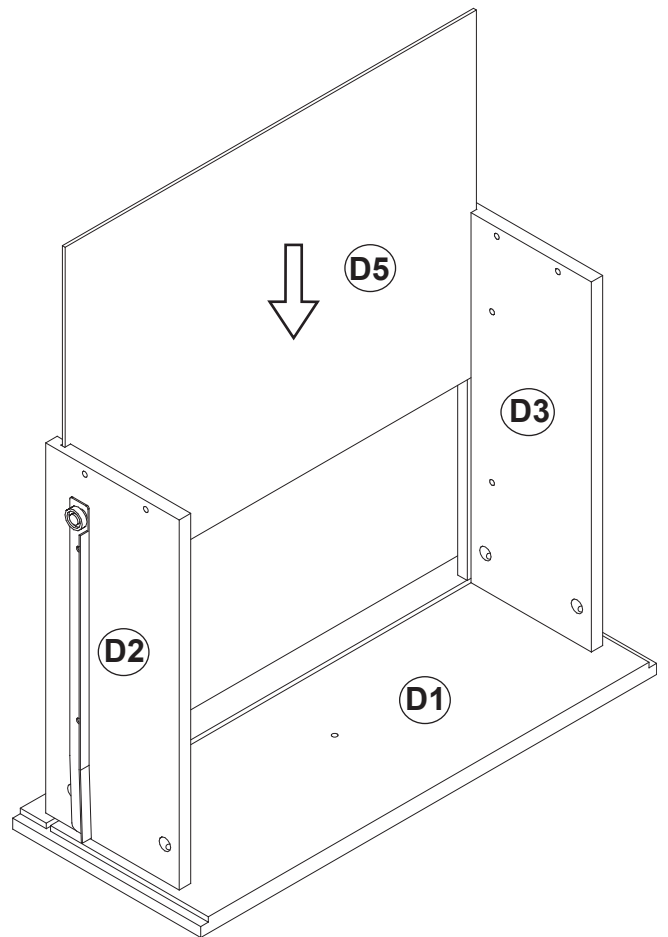
C**d**

e

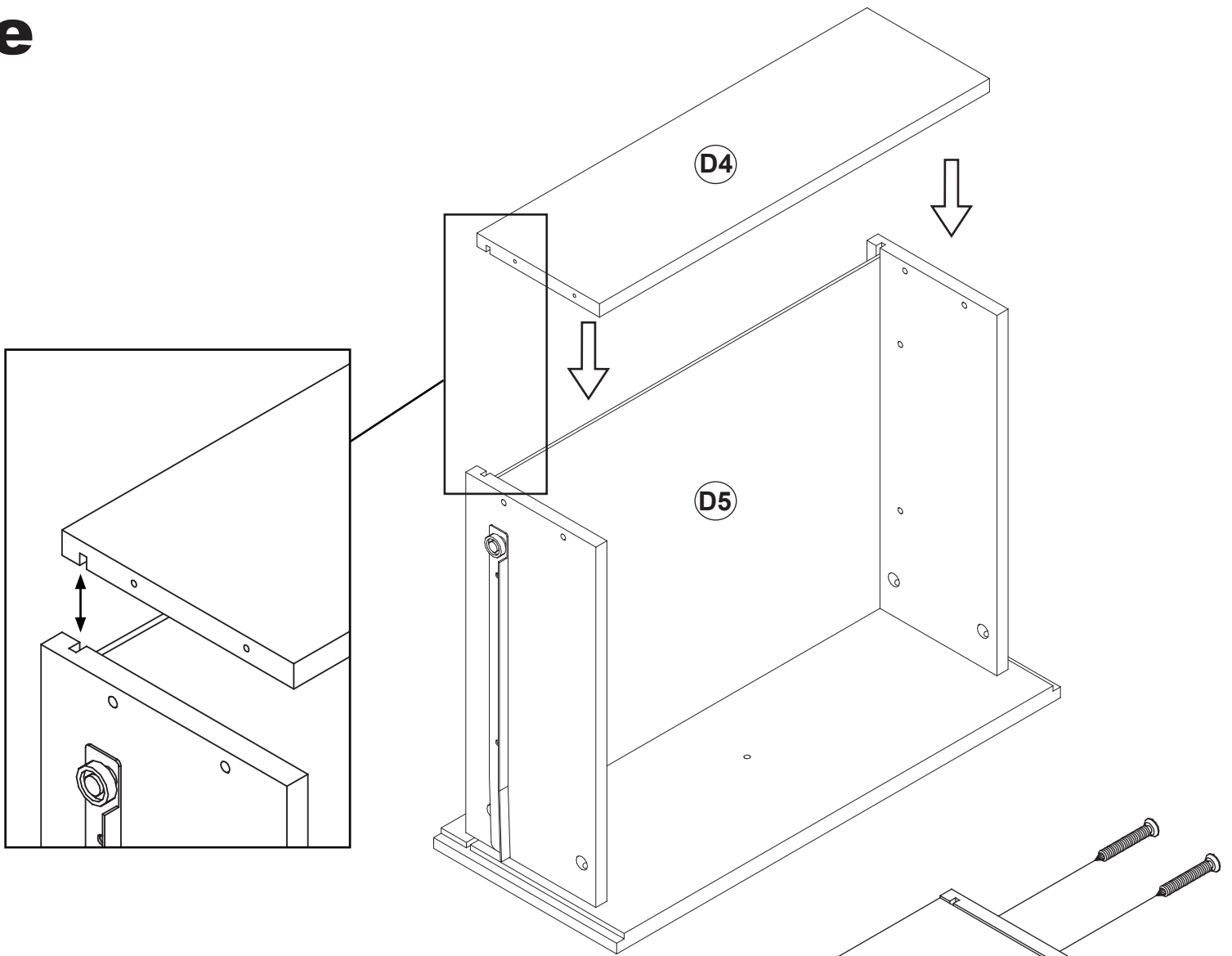

f

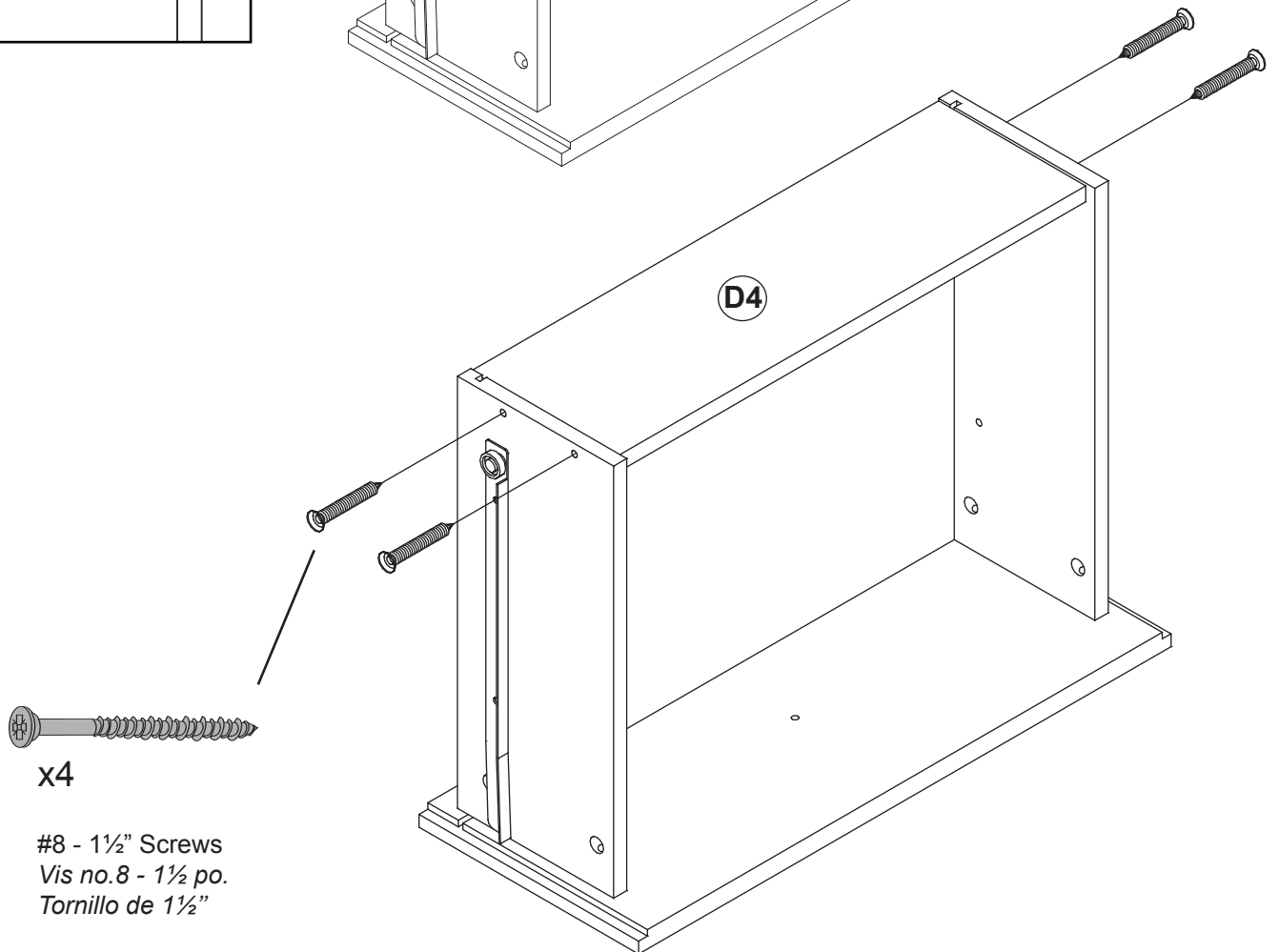

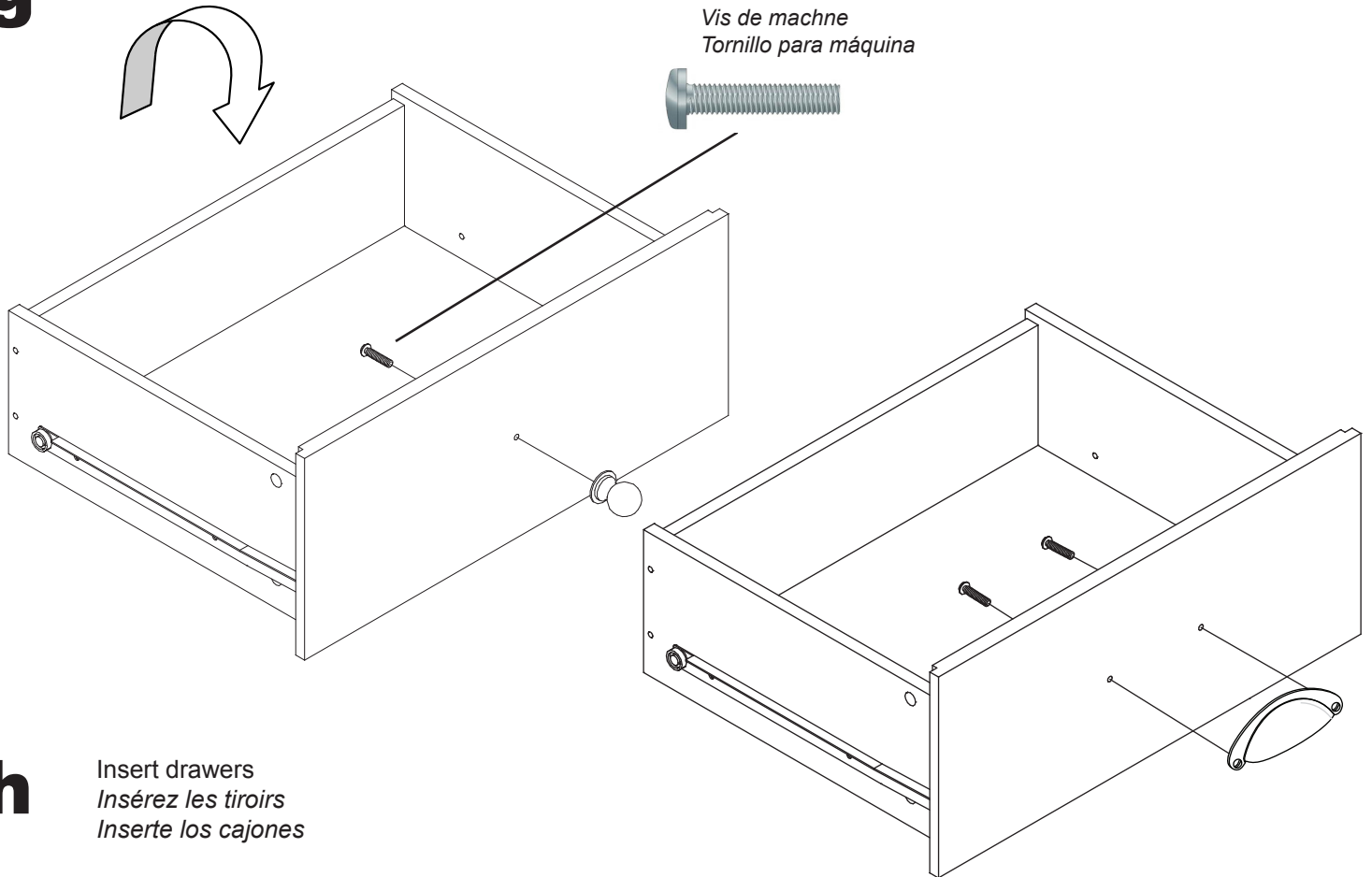
g

Machine Screw
 Vis de machine
 Tornillo para máquina

h

Insert drawers
 Insérez les tiroirs
 Inserte los cajones

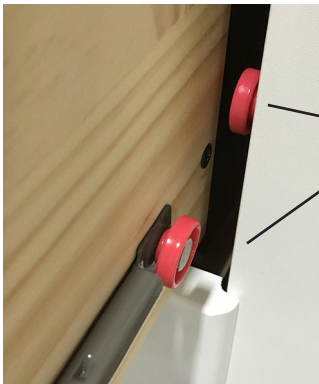

The drawer slide & cabinet slide colors will match
 La glissière du tiroir et les couleurs de la glissière de l'armoire correspondent
 Los colores de los rieles del cajón coincidirán con los colores en el mueble.

Hooded Cup Handle with Screw
 Poignée à capuchon avec vis
 Manija encapuchada con tornillos

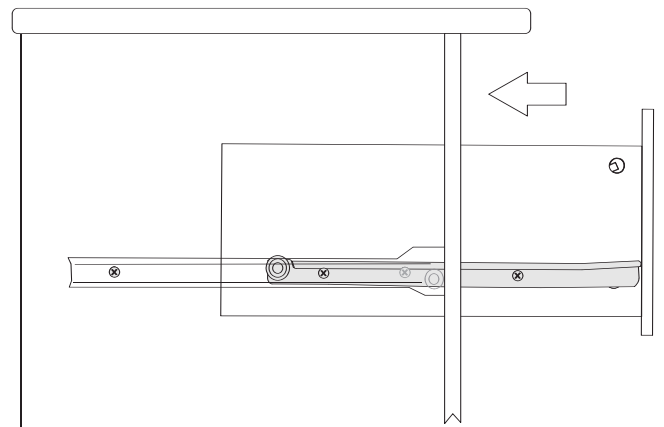
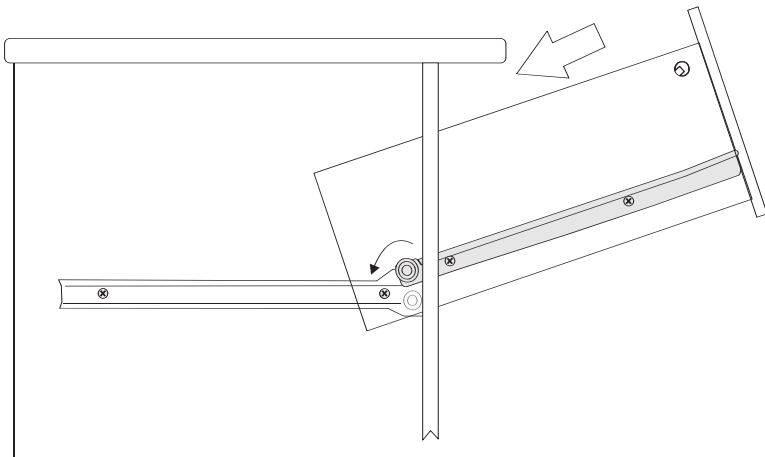

Note: When drawers are installed correctly, you will not be able to remove them without first lifting up the drawer front.

Note: Quand des tiroirs sont installés correctement, vous ne pourrez pas les enlever sans se soulever d'abord vers le haut de l'avant de tiroir.

Aviso: una vez que los cajones se hayan instalado correctamente, no podrá sacarlos sin antes levantar la parte frontal del cajón.