

Progressive®
furniture

ASSEMBLY INSTRUCTION

Item No: 1729-27/-28/-29

Description: WICKER SOFA SET

IMPORTANT NOTE:

- Place all parts on a clean and smooth surface such as a rug or carpet to avoid the parts from being scratched.
- Check to be sure that you have all parts and hardware.
- Remove all wrapping materials, including staples & packing
- Do not tighten all screws/bolts until all completely assembled.
- Keep all hardware parts out of reach of children.

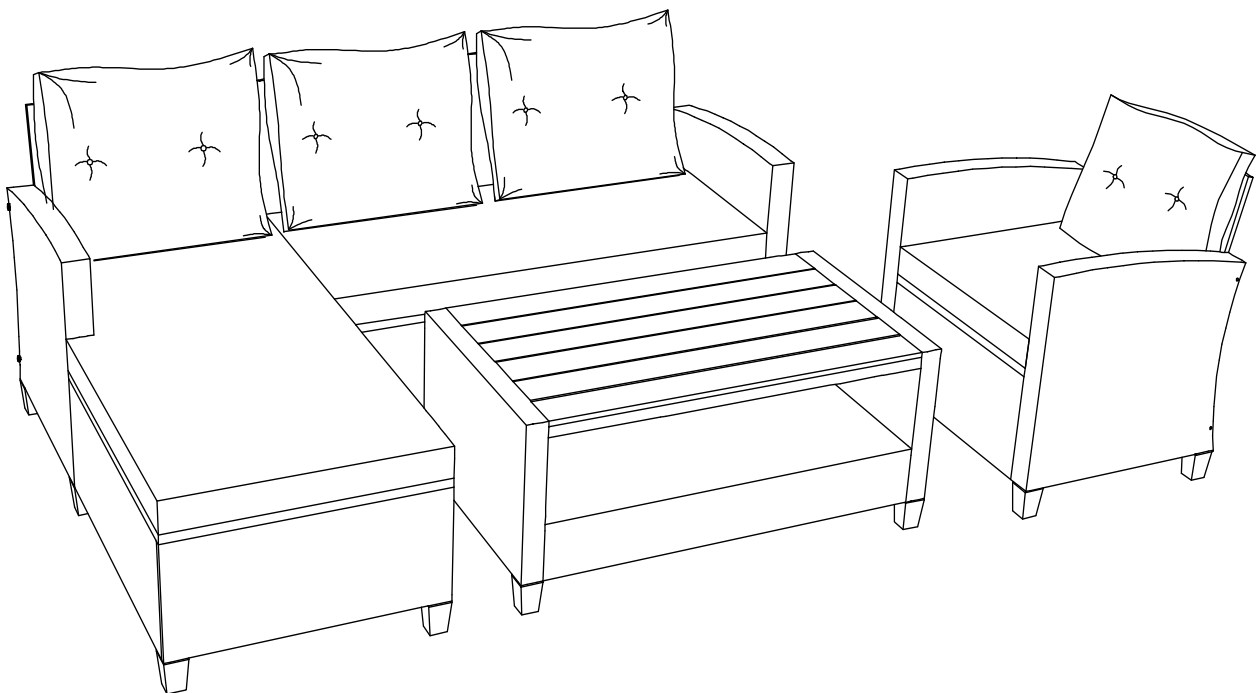

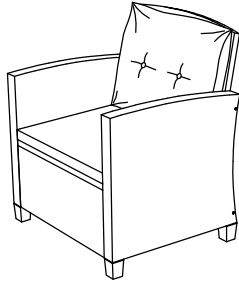

MADE IN VIETNAM







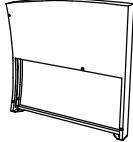
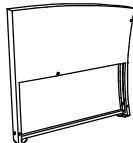
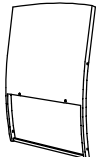
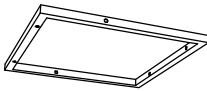
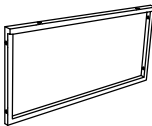

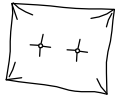

IMPORTANT NOTE:

- Place all parts on a clean and smooth surface such as a rug or carpet to avoid the parts from being scratched.
- Check to be sure that you have all parts and hardware.
- Remove all wrapping materials, including staples & packing
- Do not tighten all screws/bolts until all completely assembled.
- Keep all hardware parts out of reach of children.

Arm Chair

I729	PART LIST		
	NO.	DESCRIPTION	QTY.
- 29	A	 Right Arm	1 PC
- 29	B	 Left Arm	1 PC
- 29	C	 Single Backrest	1 PC
- 29	D	 Single Seatbase	1 PC
- 29	E	 Single Front Panel	1 PC
- 29	F	 Single Cushion Seat	1 PC
- 29	H	 Pillow	1 PC

(I729-29) HARDWARE LIST			
NO.	DESCRIPTION		QTY.
1		Bolt Ø 6 x 45mm	4 PCS
2		Bolt Ø 6 x 40mm	4 PCS
3		Bolt Ø 6 x 70mm	4 PCS
4		Bolt Ø 6 x 55mm	4 PCS
5		Washer Ø6 x 14 mm	12 PCS
6		Plastic leg 48 x 48 x 65mm	4 PCS
10		Lock Washer Ø6x10 mm	12 PCS
11		Allen key 4 x 60mm	1 PC

STEP 1:

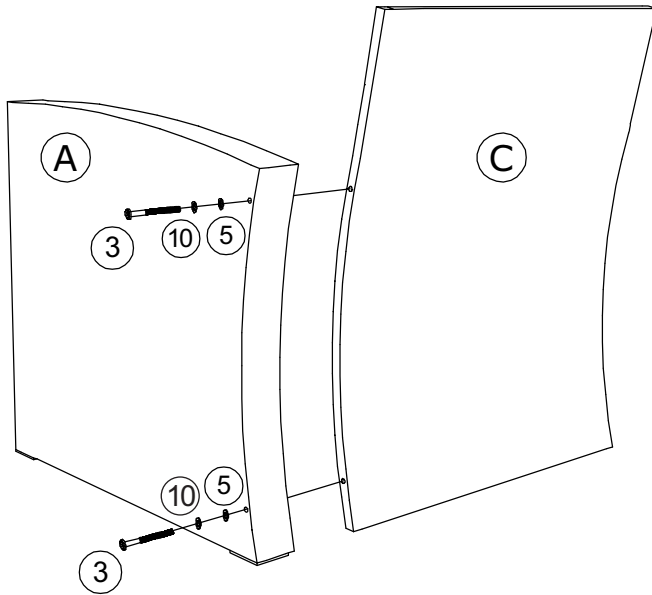

Do not tighten
all screws/bolts

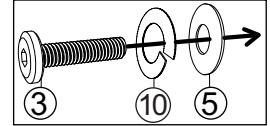
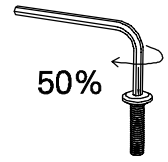

STEP 2:

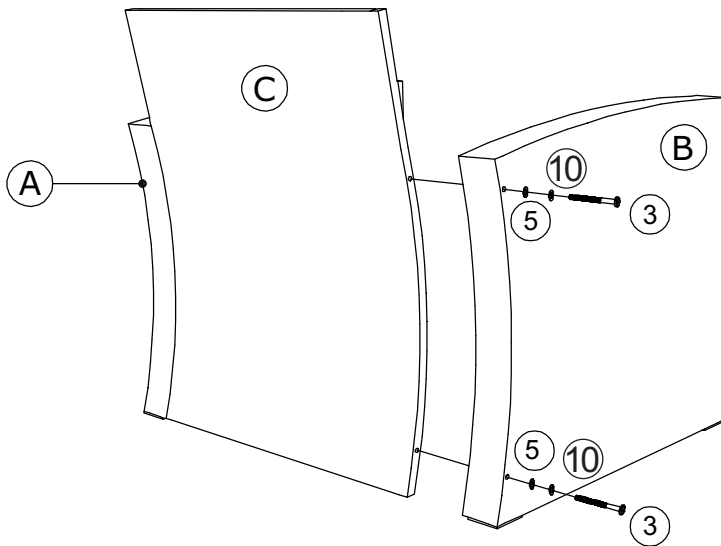

Do not tighten
all screws/bolts

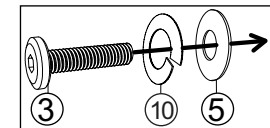
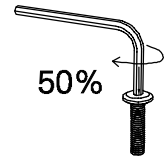

STEP 3:

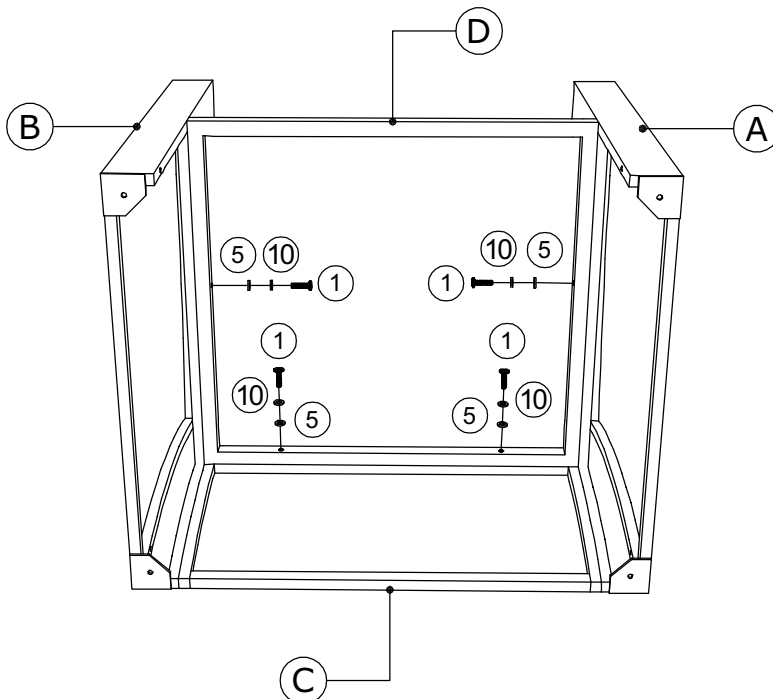

Tighten all
screws/bolts

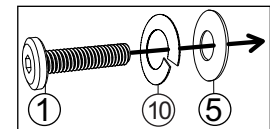
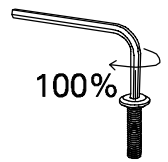

STEP 4:

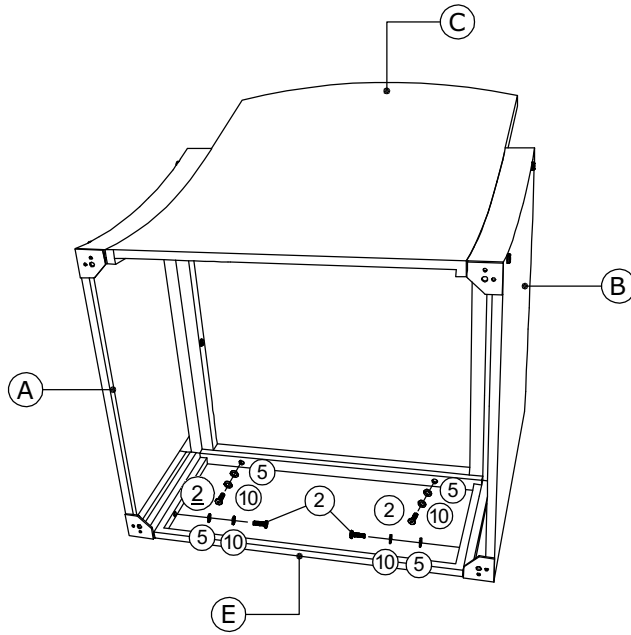

Do not tighten
all screws/bolts

50%

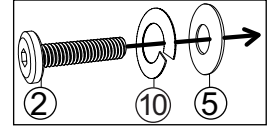

STEP 5:

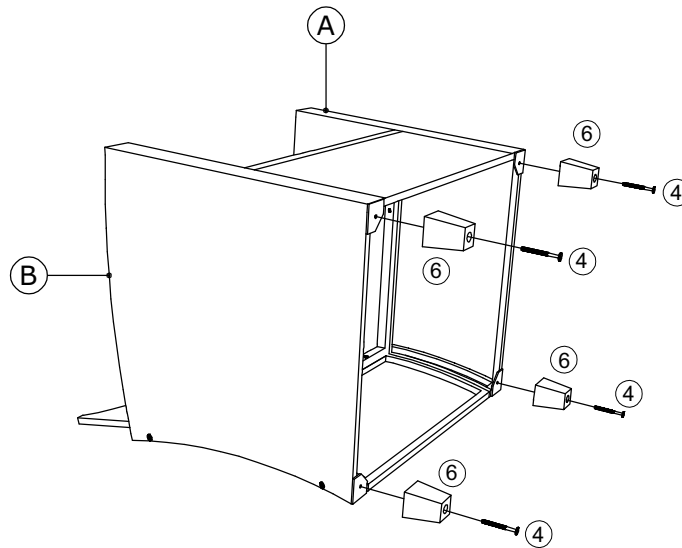

Tighten all
screws/bolts

100%

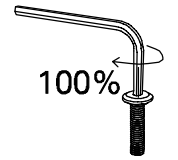

STEP 6:

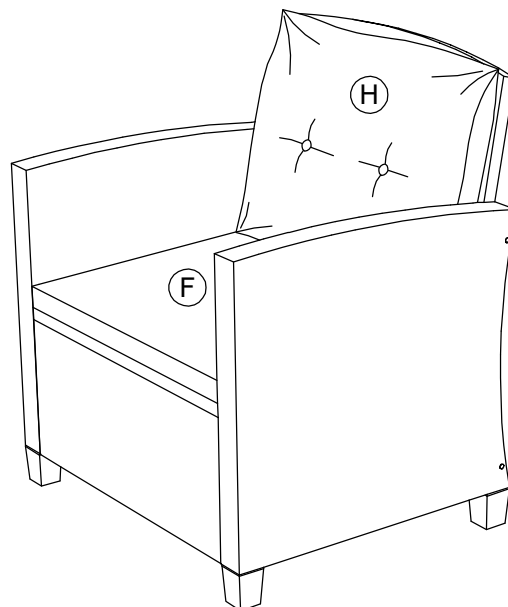

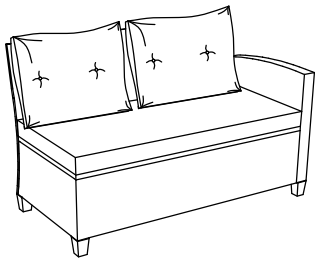







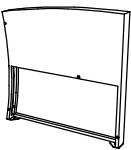
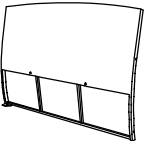

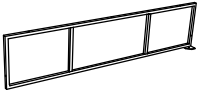
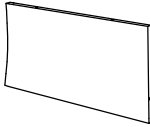

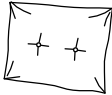

IMPORTANT NOTE:

- Place all parts on a clean and smooth surface such as a rug or carpet to avoid the parts from being scratched.
- Check to be sure that you have all parts and hardware.
- Remove all wrapping materials, including staples & packing
- Do not tighten all screws/bolts until all completely assembled.
- Keep all hardware parts out of reach of children.

Two Seater Bench

1729	PART LIST		
	NO.	DESCRIPTION	QTY.
- 28	A	 Right Arm	1 PC
- 28	G	 Two Seater Backrest	1 PC
- 28	J	 Two Seater Seatbase	1 PC
- 28	L	 Two Seater Front Panel	1 PC
- 28	N	 Two Seater Side Panel	1 PC
- 28	M	 Two Seater Cushion	1 PC
- 28	H	 Pillow	2 PCS

(1729-28) HARDWARE LIST		
NO.	DESCRIPTION	QTY.
1	 Bolt Ø 6 x 45mm	6 PCS
2	 Bolt Ø 6 x 40mm	5 PCS
3	 Bolt Ø 6 x 70mm	2 PCS
4	 Bolt Ø 6 x 55mm	4 PCS
5	 Washer Ø6 x 14 mm	13 PCS
6	 Plastic leg 48 x 48 x 65mm	4 PCS
10	 Lock Washer Ø6x10 mm	13 PCS
11	 Allen key 4 x 60mm	1 PC

STEP 1:

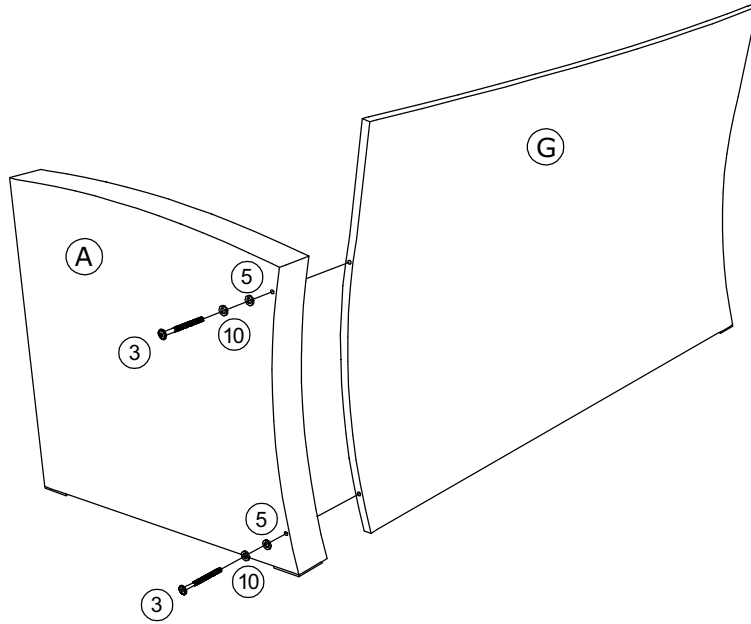

Do not tighten
all screws/bolts

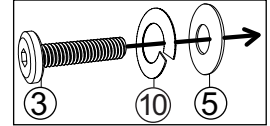
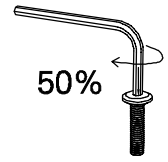

STEP 2:

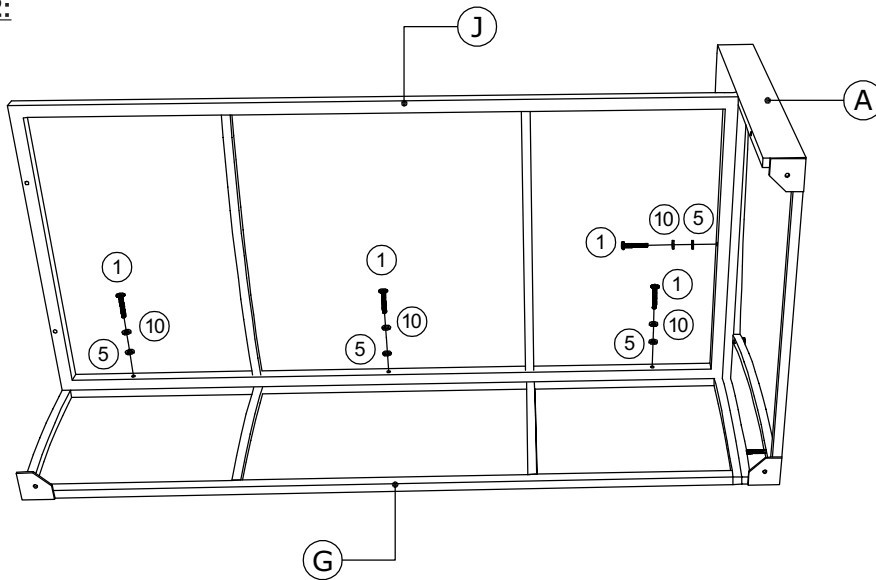

Do not tighten
all screws/bolts

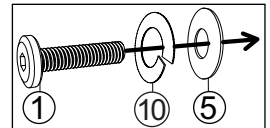
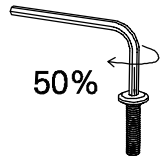

STEP 3:

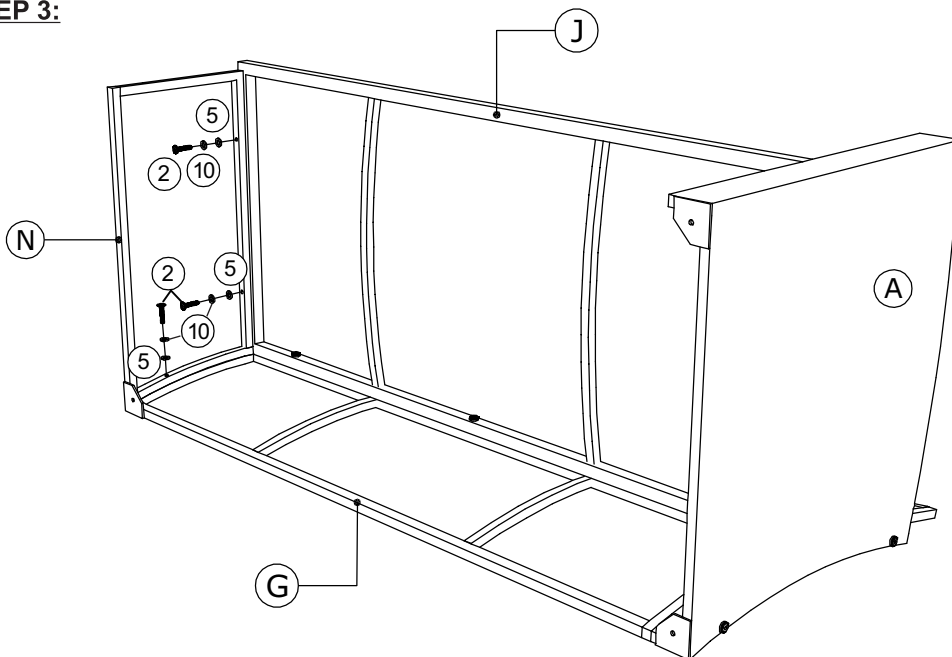

Tighten all
screws/bolts

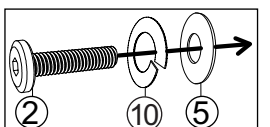
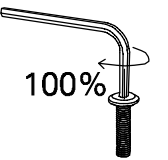

STEP 4:

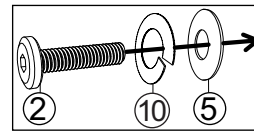
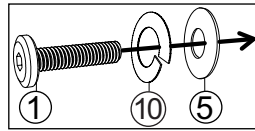

Do not tighten
all screws/bolts

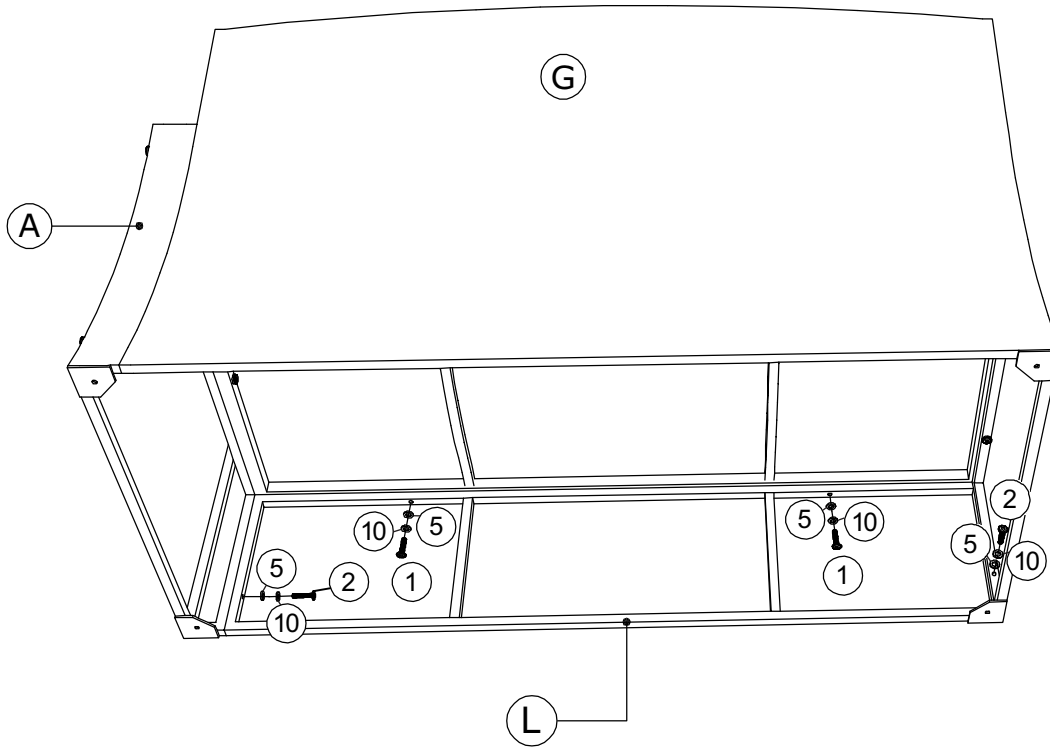
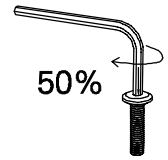

STEP 5:

Tighten all
screws/bolts

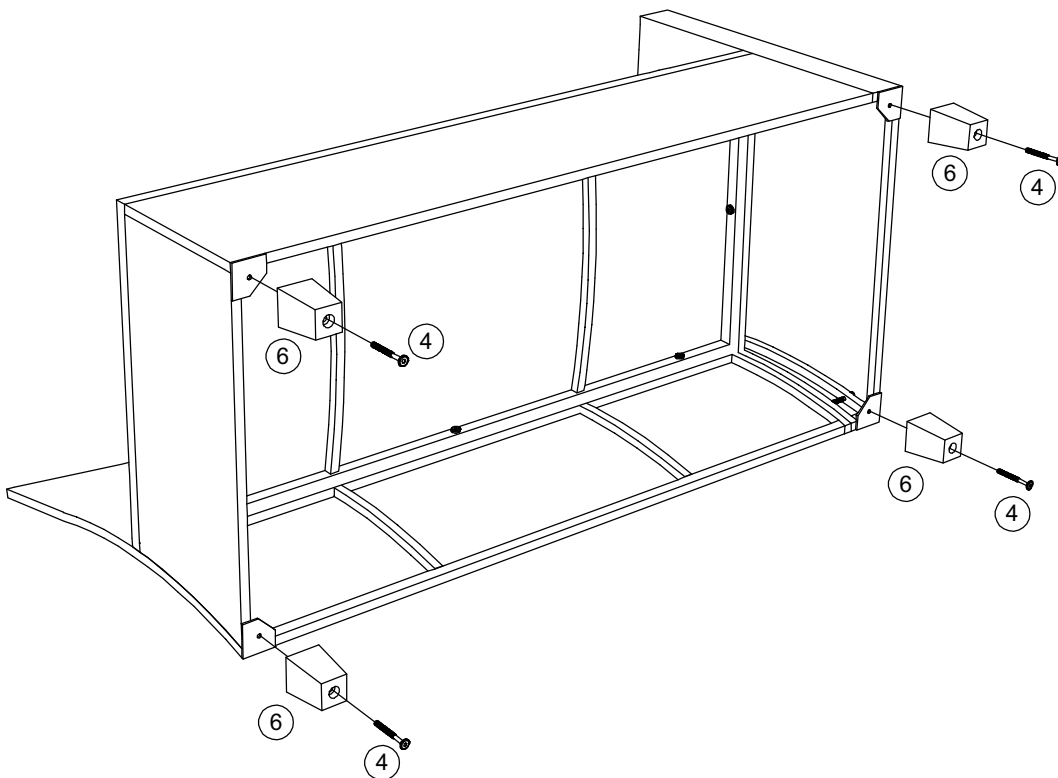
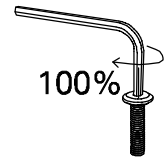

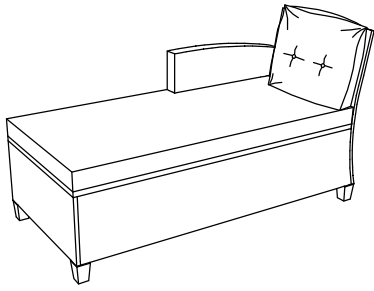







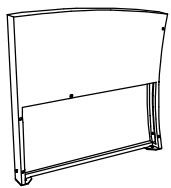
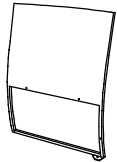
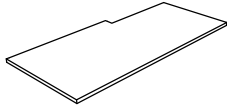
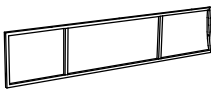
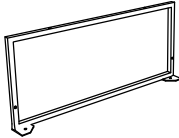
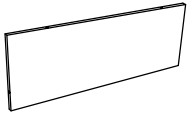
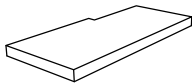
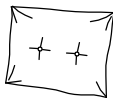



IMPORTANT NOTE:

- Place all parts on a clean and smooth surface such as a rug or carpet to avoid the parts from being scratched.
- Check to be sure that you have all parts and hardware.
- Remove all wrapping materials, including staples & packing
- Do not tighten all screws/bolts until all completely assembled.
- Keep all hardware parts out of reach of children.

Lounger

1729	PART LIST		
	NO.	DESCRIPTION	QTY.
- 27	B	 Left Arm	1 PC
- 27	Q	 Lounger Backrest	1 PC
- 27	R	 Lounger Seat base	1 PC
- 27	S	 Lounger Large Side Panel	1 PC
- 27	T	 Lounger Front Panel	1 PC
- 27	K	 Lounger Small Side Panel	1 PC
- 27	U	 Lounger Cushion Seat	1 PC
- 27	H	 Pillow	1 PC

(1729-27) HARDWARE LIST			
NO.	DESCRIPTION	QTY.	
1	 Bolt Ø 6 x 45mm	6 PCS	
2	 Bolt Ø 6 x 40mm	8 PCS	
3	 Bolt Ø 6 x 70mm	2 PCS	
4	 Bolt Ø 6 x 55mm	5 PCS	
5	 Washer Ø6 x 14 mm	16 PCS	
6	 Plastic leg 48 x 48 x 65mm	5 PCS	
7	 Connection 62 x 40 x 32mm	2 PCS	
10	 Lock Washer Ø6x10 mm	16 PCS	
11	 Allen key 4 x 60mm	1 PC	

STEP 1:

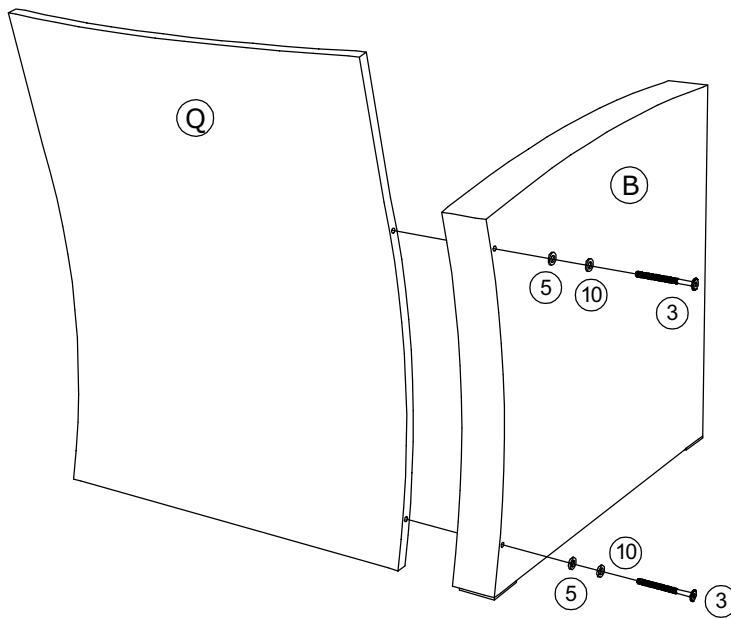

Do not tighten
all screws/bolts

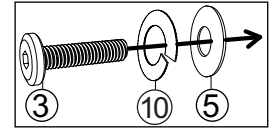
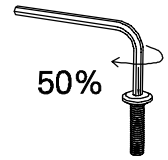

STEP 2:

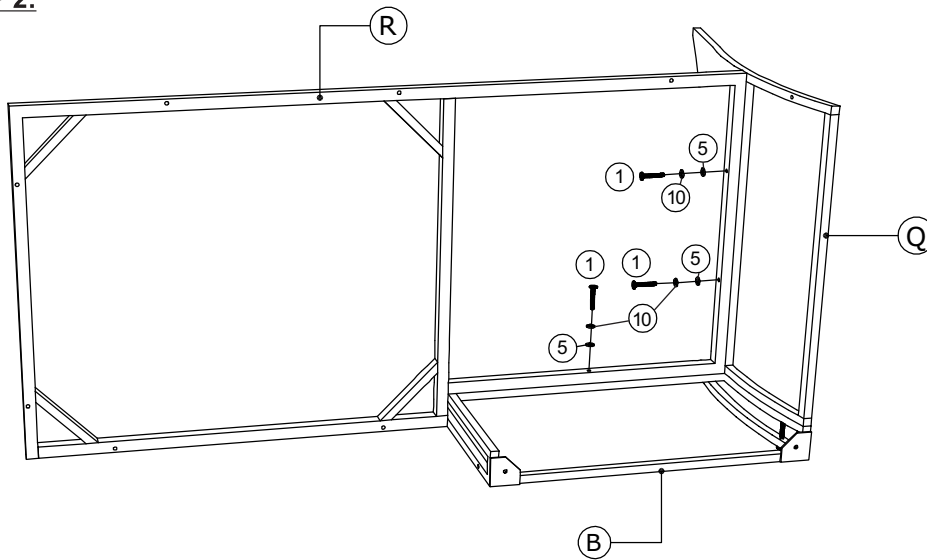

Do not tighten
all screws/bolts

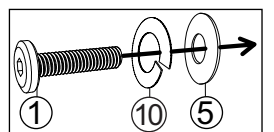
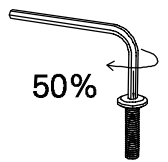

STEP 3:

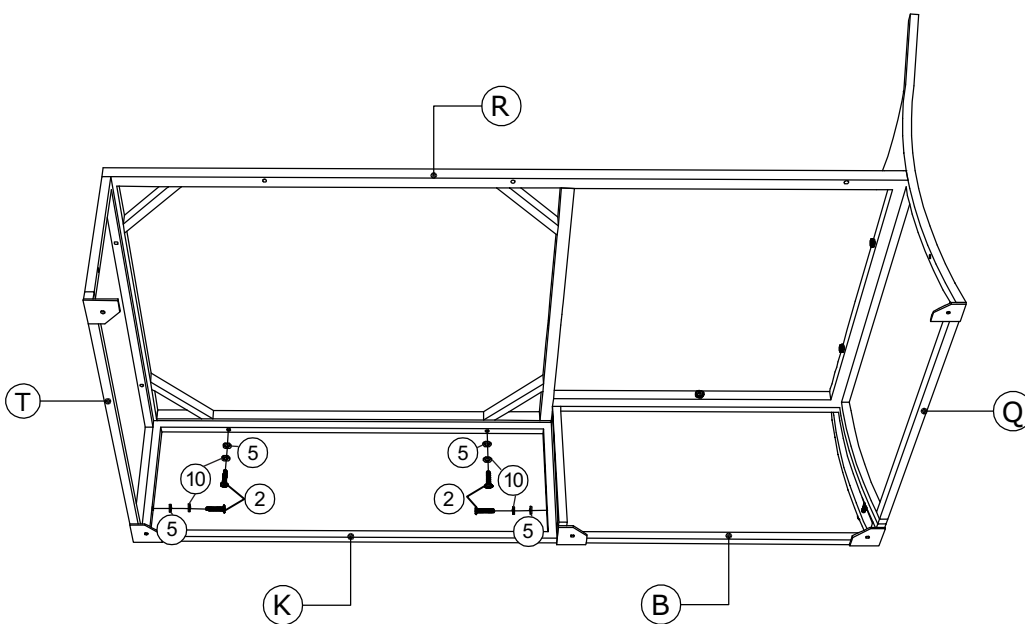

Tighten all
screws/bolts

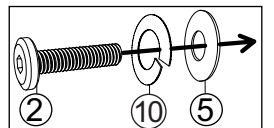
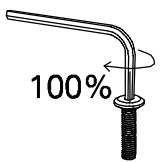

STEP 4:

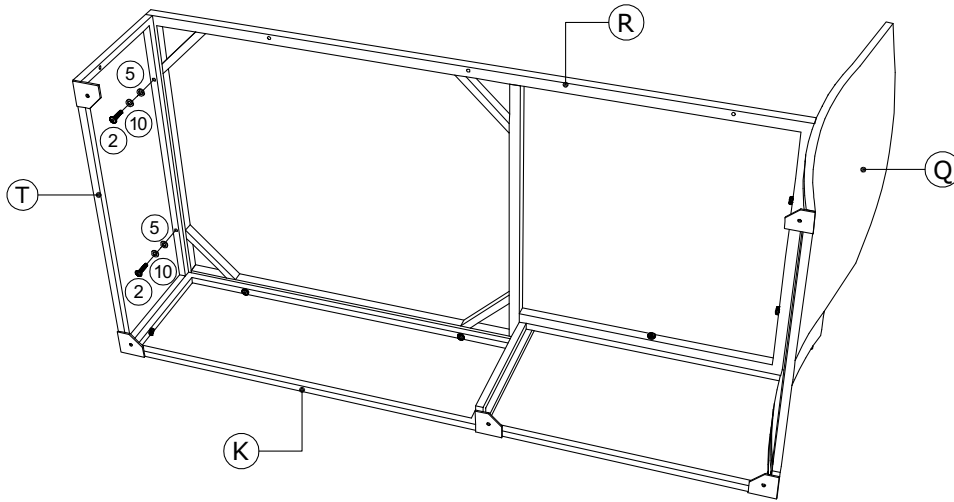

Do not tighten
all screws/bolts

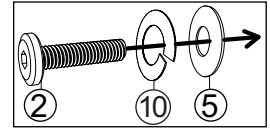
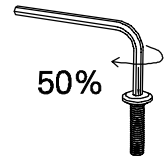

STEP 5:

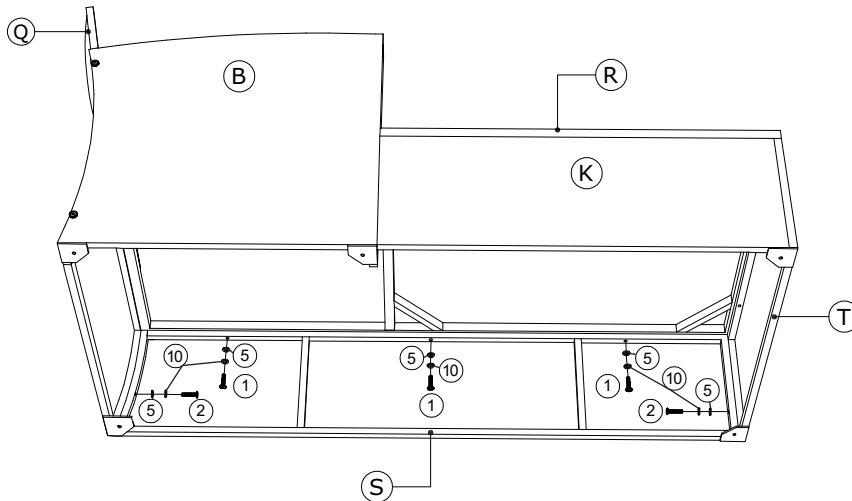

Tighten all
screws/bolts

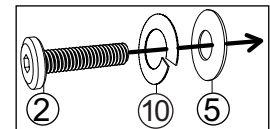
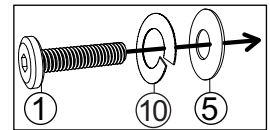

STEP 6:

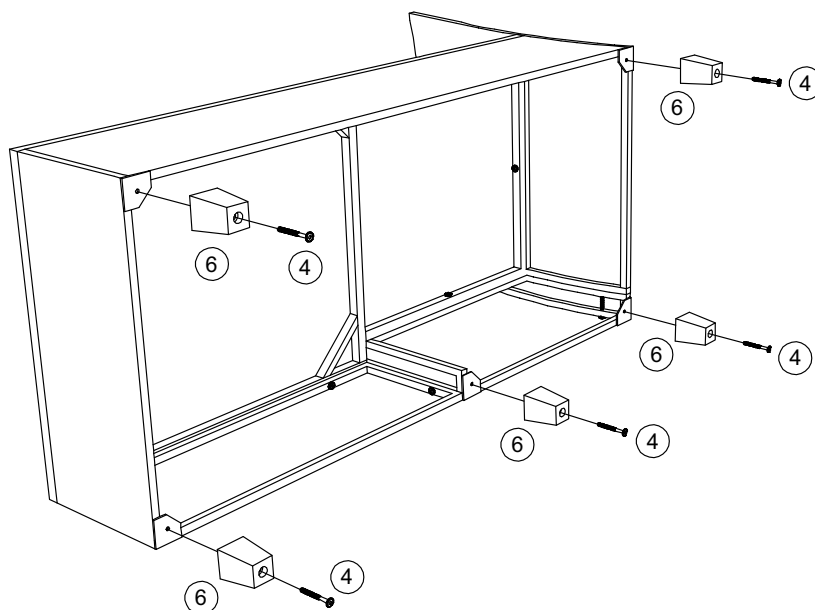

Tighten all
screws/bolts



STEP 7:

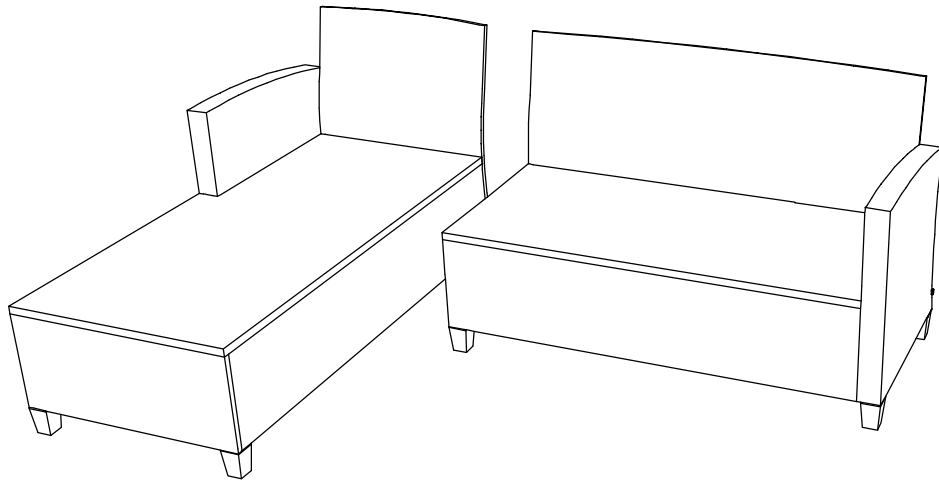

Tighten all
screws/bolts

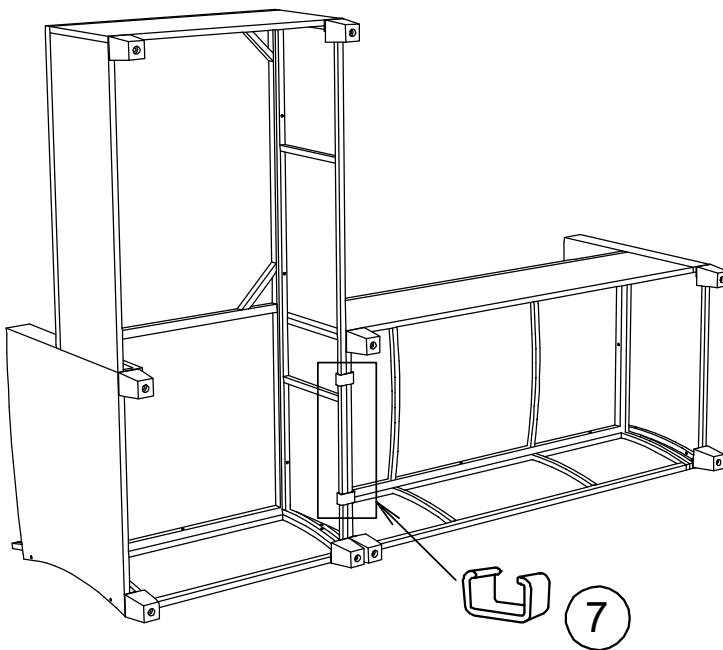

STEP 8:

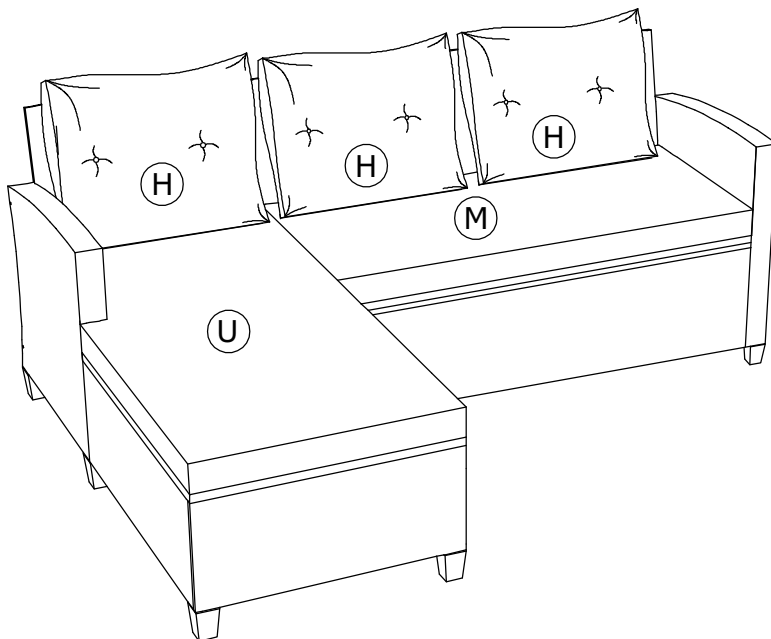

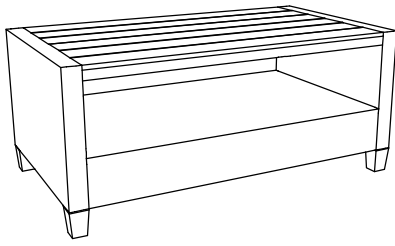







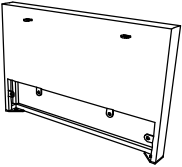
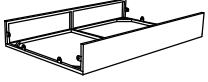
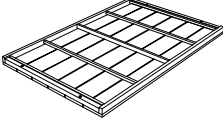

IMPORTANT NOTE:

- Place all parts on a clean and smooth surface such as a rug or carpet to avoid the parts from being scratched.
- Check to be sure that you have all parts and hardware.
- Remove all wrapping materials, including staples & packing
- Do not tighten all screws/bolts until all completely assembled.
- Keep all hardware parts out of reach of children.

Coffee Table

I729	PART LIST			
	NO.	DESCRIPTION	QTY.	
- 27	X		Table Leg	2 PCS
- 27	Y		Table Shelf	1 PC
- 27	W		Table Top	1 PC

(I729-27) HARDWARE LIST			
NO.	DESCRIPTION		QTY.
8		Bolt Ø 6 x 25mm	8 PCS
5		Washer Ø6 x 14 mm	12 PCS
4		Bolt Ø 6 x 55mm	4 PCS
6		Plastic leg 48 x 48 x 65mm	4 PCS
9		Bolt Ø 6 x 20mm	4 PCS
10		Lock Washer Ø6x10 mm	4 PCS
11		Allen key 4 x 60mm	1 PC

STEP 1:

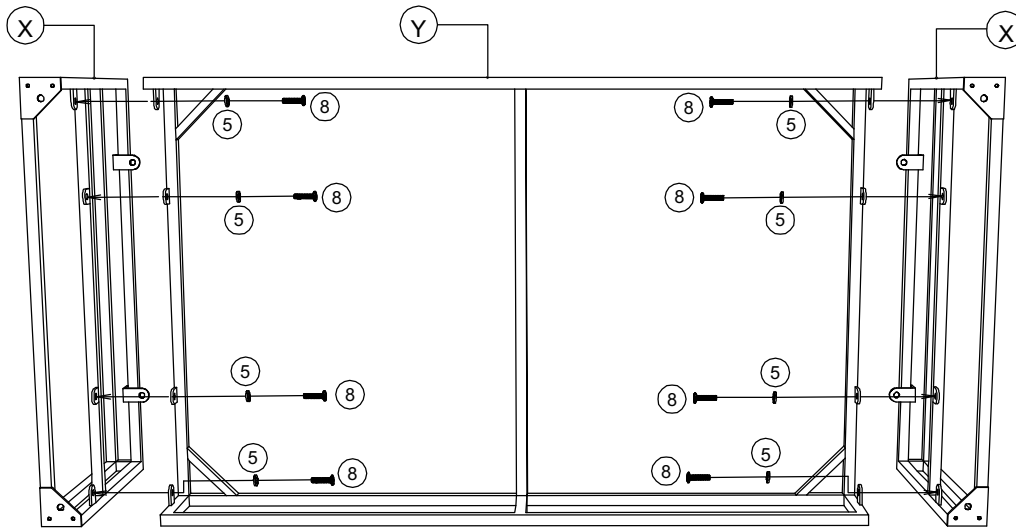

Do not tighten
all screws/bolts

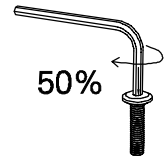

STEP 2:

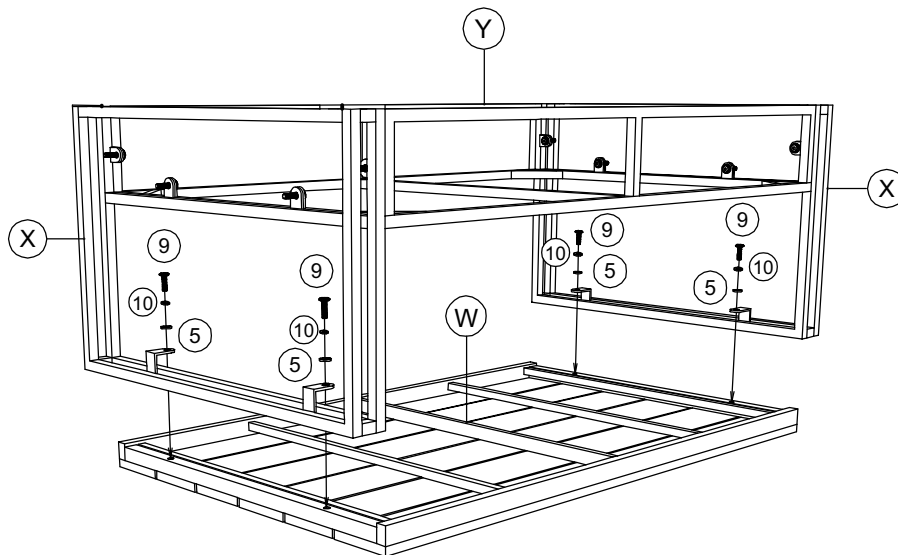

Do not tighten
all screws/bolts

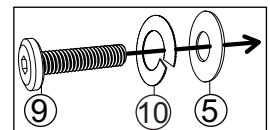
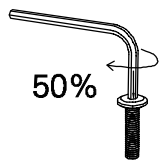

STEP 3:

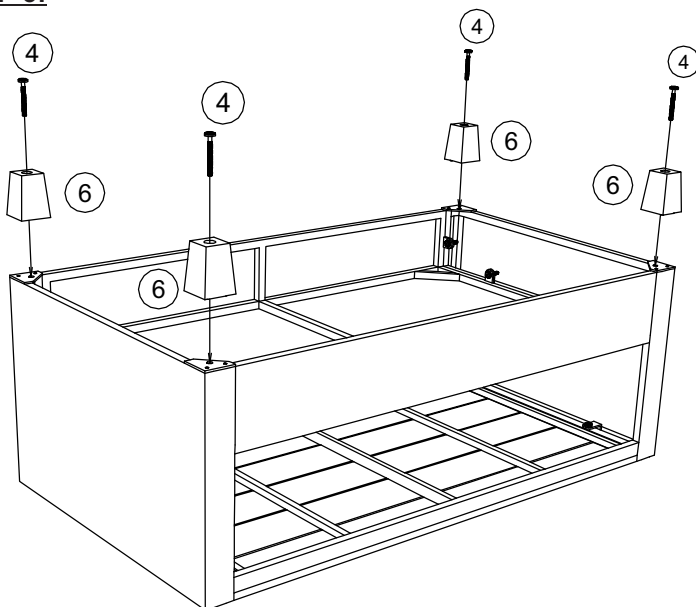

Tighten all
screws/bolts

