

ASSEMBLY INSTRUCTIONS

PRAIRIE PARSON CHAIR

ITEM NO.:1568-02-3A
 DIMENSION:W21.65" x D25.98" x H 36.61"

PART LIST

(A) Back assembly
(1pc)



(B) Front legs-(2pcs)
(put inside seat cushion)

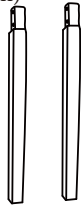

(C) Back legs-(2pcs)
(put inside seat cushion)



DO NOT FULLY TIGHTEN SCREWS AND BOLTS UNTIL THE ENTIRE ITEM IS COMPLETELY ASSEMBLED

NOTICE

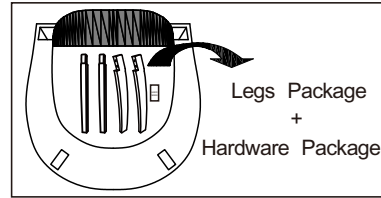

STEP 1

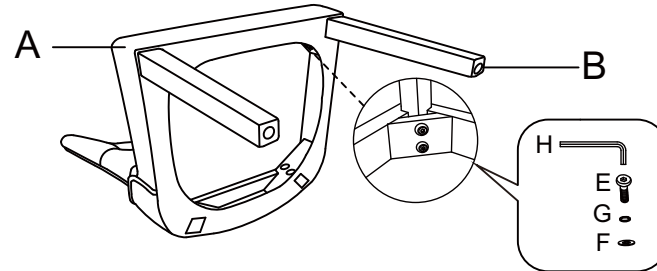

Step1:Put the screws in the holes,tighten the screws,but not too tighten,90% is ok.

STEP 2

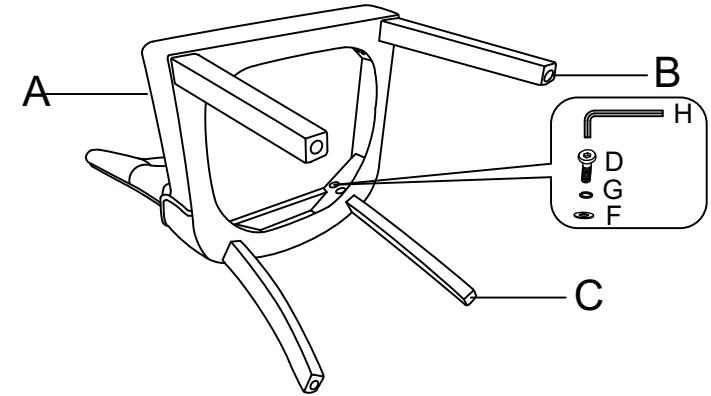

Step 2:Put the screws in the holes,tighten the screws,but not too tighten,90% is ok.

HARDWARE LIST

Screw D



(1) M8X55MM
(4PCS)

Screw E



(2) M8X65MM
(4PCS)

Flat washer F



(3) 8pcs

Spring washer G



(4) 8pcs

Allen key H



(5) M8
1PC

STEP 3

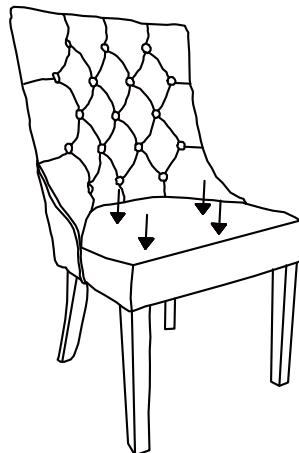

Step 3: Then adjust the balance of this chair,tighten all the screws to100%.

STEP 4

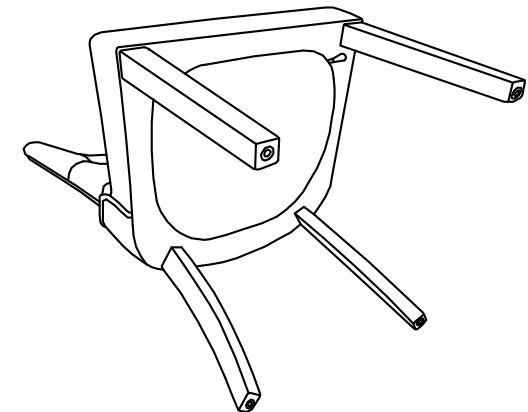

Step4 :Finally,stick the non-woven cover underneath the seat.