

**\*ATTENTION\***

All parts are  
inside the Headboard

**ASSEMBLY INSTRUCTION**

ITEM : B135/B136/B137 TWIN BED		
NO	PART LIST	QTY
1	HEAD BOARD CUSHION	1pc
2	RIGHT HEAD BOARD LEG (WITH "R" LABEL)	1pc
3	LEFT HEAD BOARD LEG (WITH "L" LABEL)	1pc
4	FOOT BOARD CUSHION	1pc
5	FOOT BOARD LEG	2pcs
6	(left) SIDE RAIL	2pcs
7	(right) SIDE RAIL	2pcs
8	CLEAT	4pcs
9	SIDE RAIL SUPPORT	2pcs
10	SLAT	4pcs
NO	HARDWARE LIST	QTY
A	JCBB SCREW M8 x 20mm	8pcs
B	JCBC SCREW M6 x 25mm	8pcs
C	JCBC SCREW M6 x 35mm	16pcs
D	JCBC SCREW M6 x 50mm	6pcs
E	JCBC SCREW M6 x 100mm	2pcs
F	DOWEL	2pcs
G	SPRING WASHER	30pcs
H	FLAT WASHER	30pcs
I	SCREW M4 x 32mm	8pcs
J	L - KEY M5 x 65mm	1pc
K	L - KEY M4 x 100mm	1pc

**STEP 1**

**open**

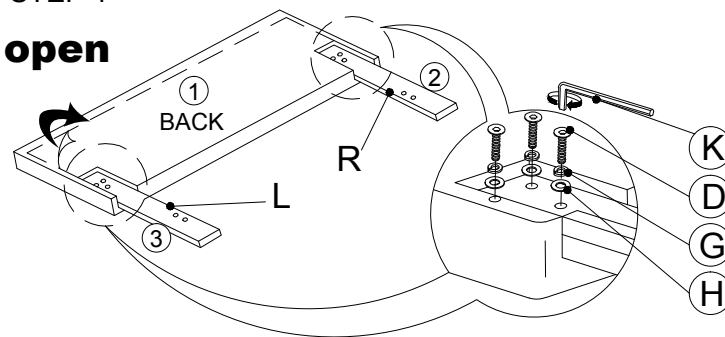

**STEP 2**

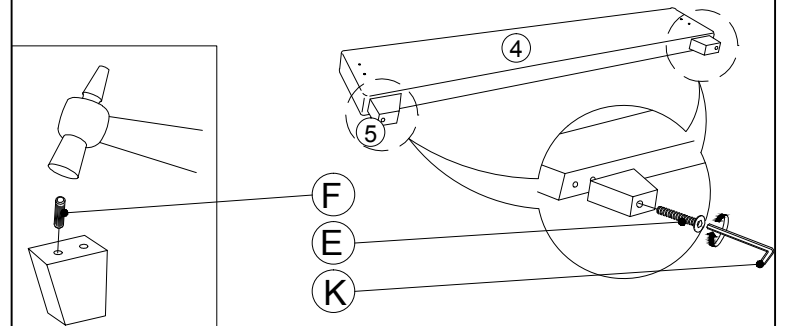

**STEP 3**

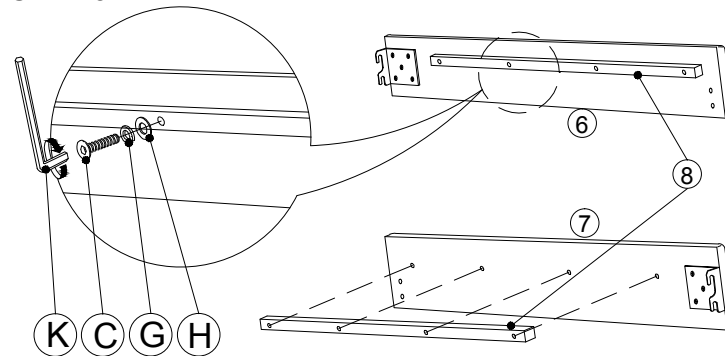

**STEP 4**

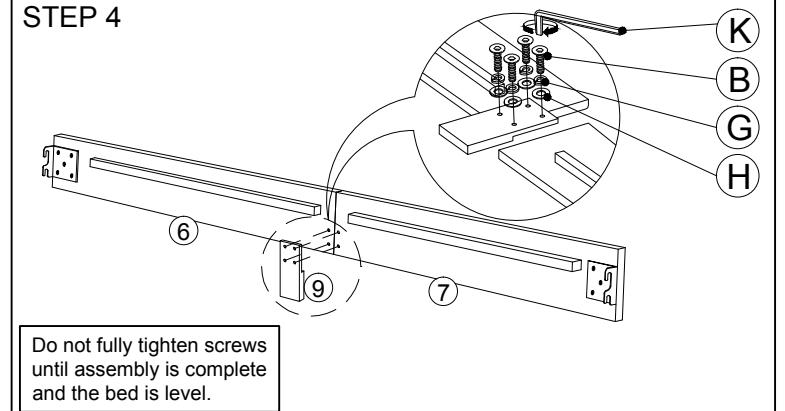

**STEP 5**

head board

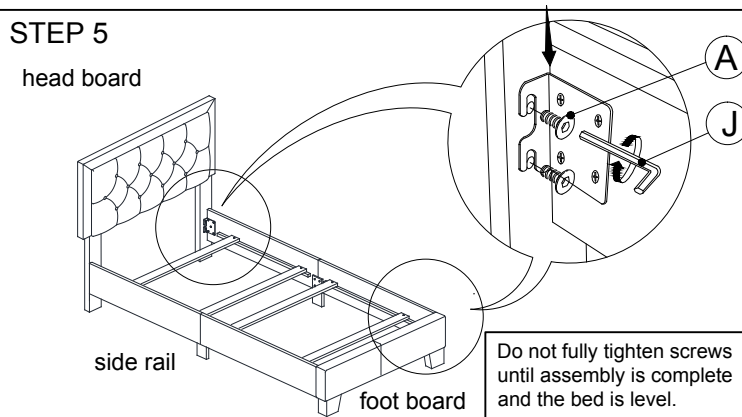

**STEP 6 (DONE)**

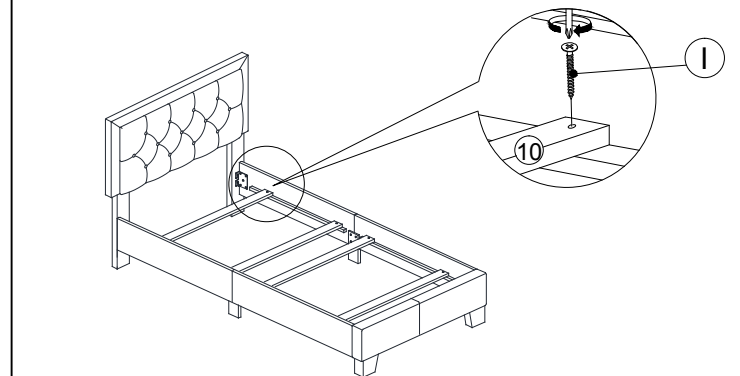

NOTE: AFTER A FEW DAYS OF ASSEMBLY, IT WILL HAVE ACCLIMATIZED TO THE ENVIRONMENT. PLEASE TIGHTEN ALL HARDWARE. CHECK TIGHTNESS OF ALL SCREWS EVERY 6-8 WEEKS.