



HARMONY

—  — SERIES

Installation Guide



888-993-3757

Assembling the table bases.

View image 1A. to identify parts.

Step 1:

Connect the post(s) to the base plate using long 1 5/8" screws.

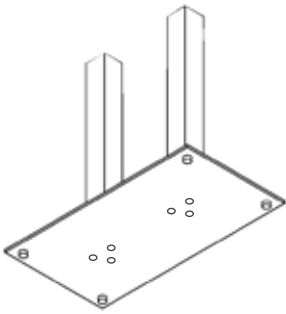

Step 2:

Connect the mounting plate to the assembled post using the 1" screws

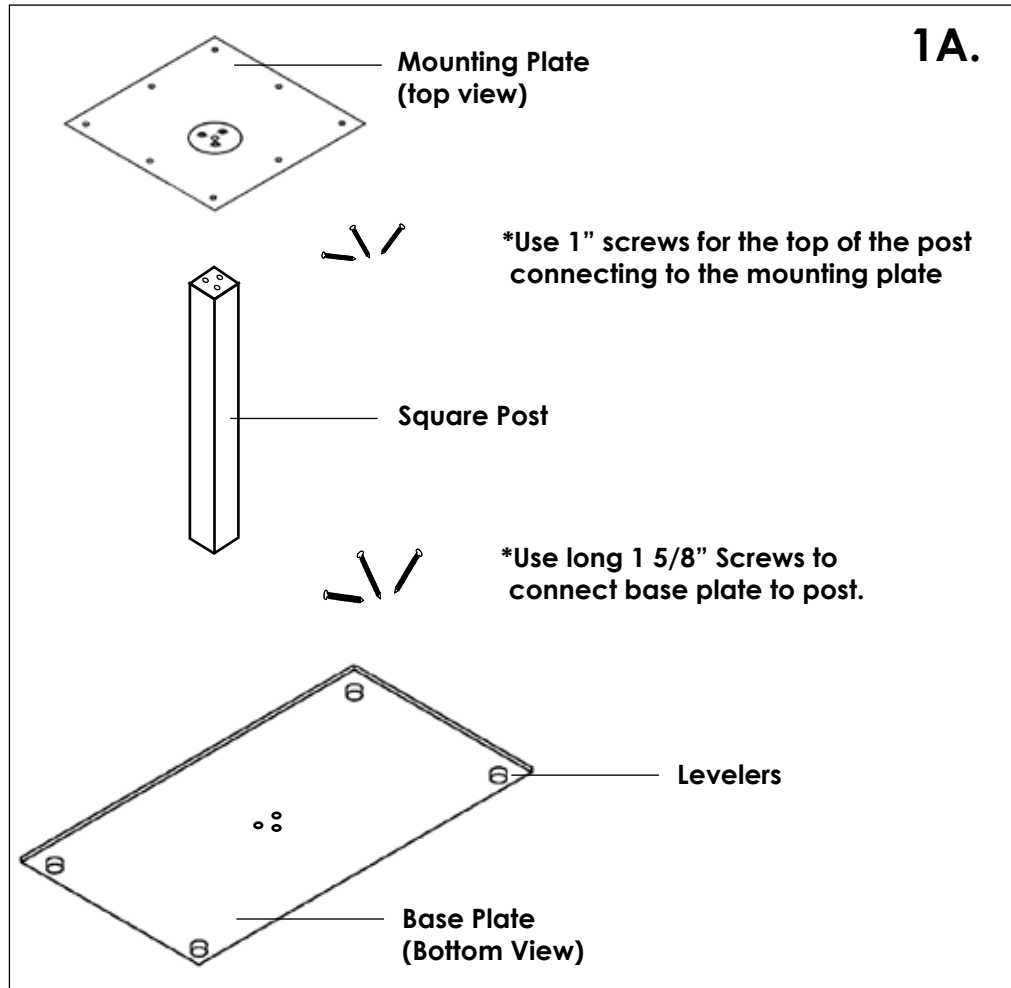
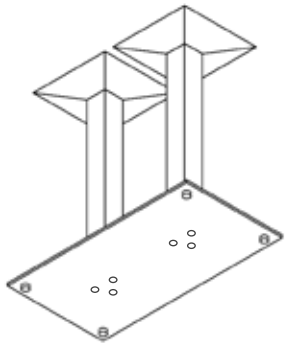

Assembled Base

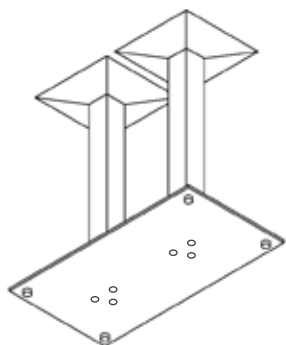

Bottom View

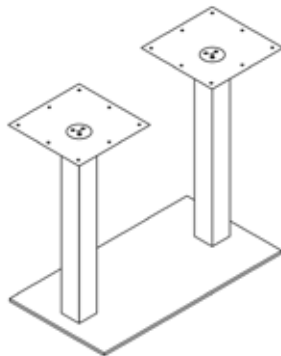

Top View

***General Instructions:**
Actual product may vary slightly

Installation

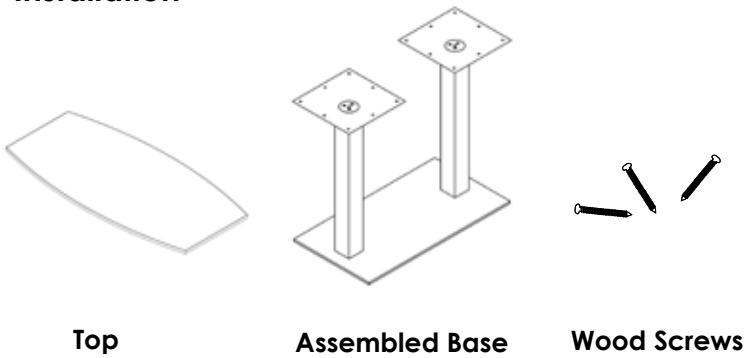

Step 1:

Turn over top to be able to screw in the base.

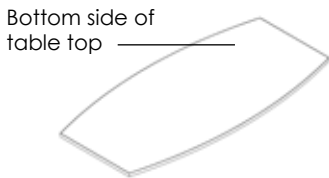

Step 2:

Next place the side of the base with the holes on to the top and make sure it is centered.

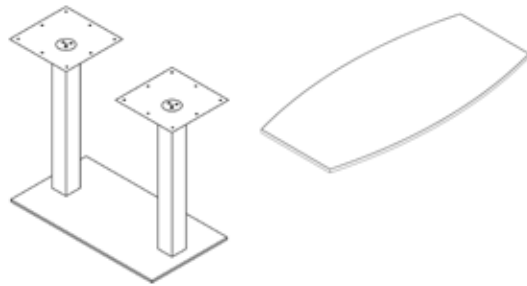

Step 3:

Screw the base to the worksurface using screws that are provided.

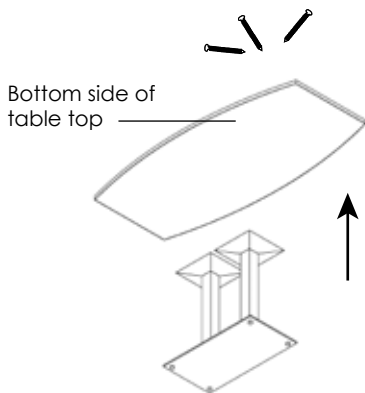

Step 4:

Stand table right side up.

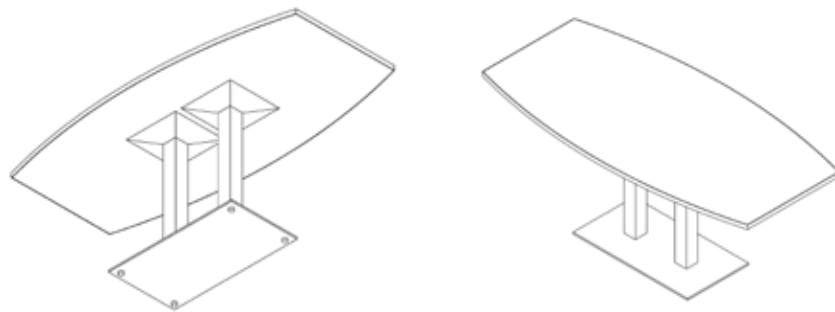

***General Instructions:**
Actual product may vary slightly

Installation for 2 or more bases with two table tops

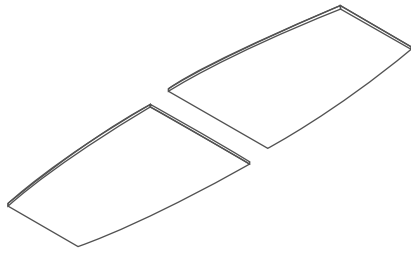

Top



Flat Bracket

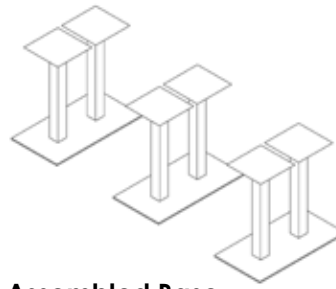

Assembled Base



Wood Screws

Step 1:

Turn over tops and slide together to be able to screw in the bases.

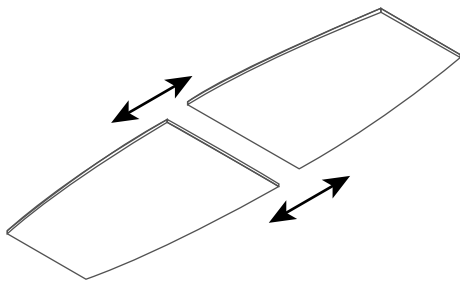

Step 2:

Next place one base on each table top and center it. Attach bases by the side with the holes on to the top. Screw the bases into the top.

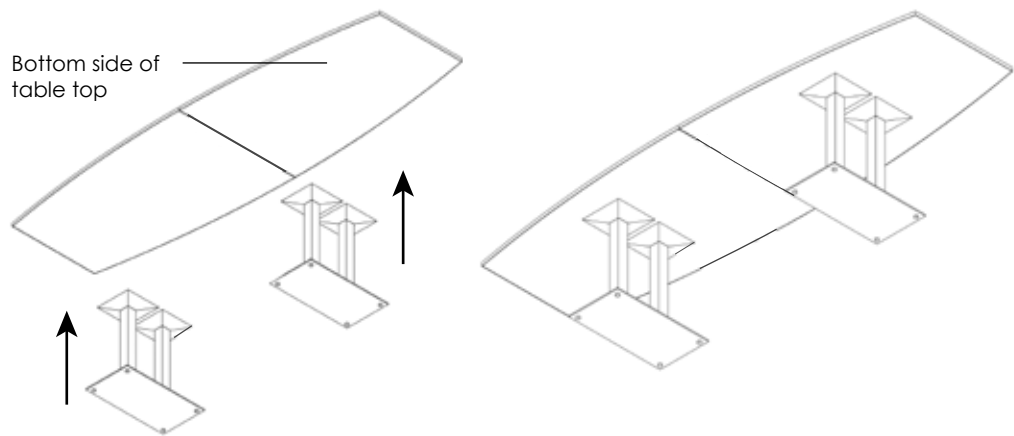

Step 3:

After the two bases are attached, place flat brackets on the connecting line of the tops at an angle (see image below). Then screw into place.

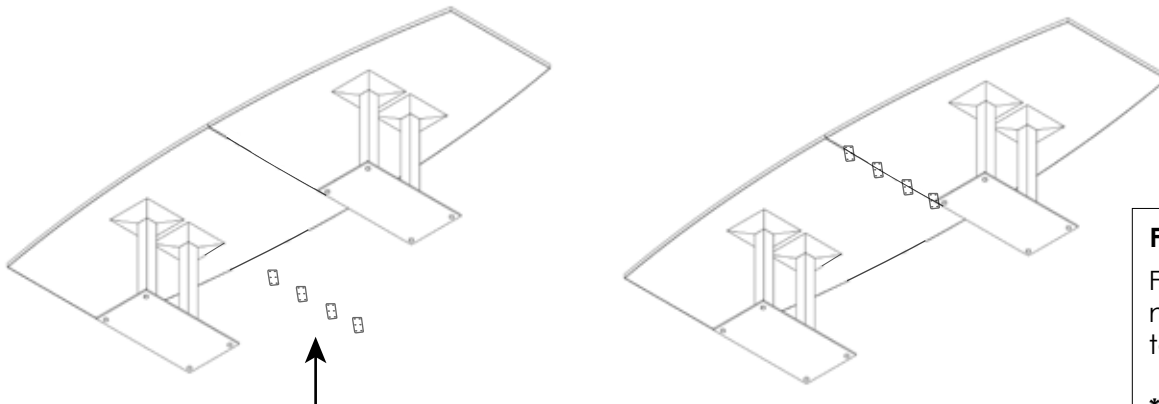

Flat Bracket
Flat Brackets will be needed on certain size tables for extra support.
***Make sure flat brackets are secure before attaching a third base or standing table upright.**

Step 4:

For large tables a third base may be needed. If so, connect base to top at the middle of the table.

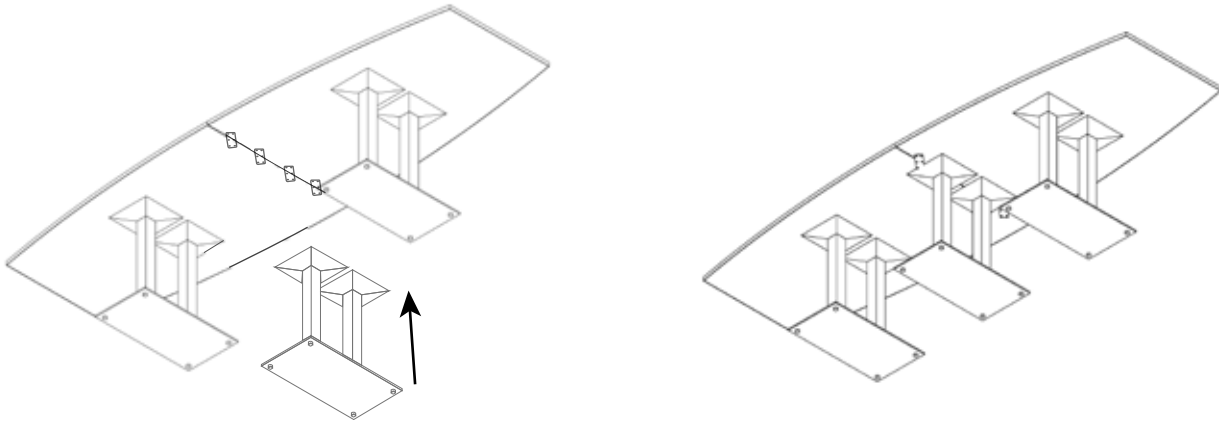

Step 5:

Stand table right side up.

